

DLP-232PC
LEAD-FREE

MINIATURE USB - MICROCONTROLLER MODULE

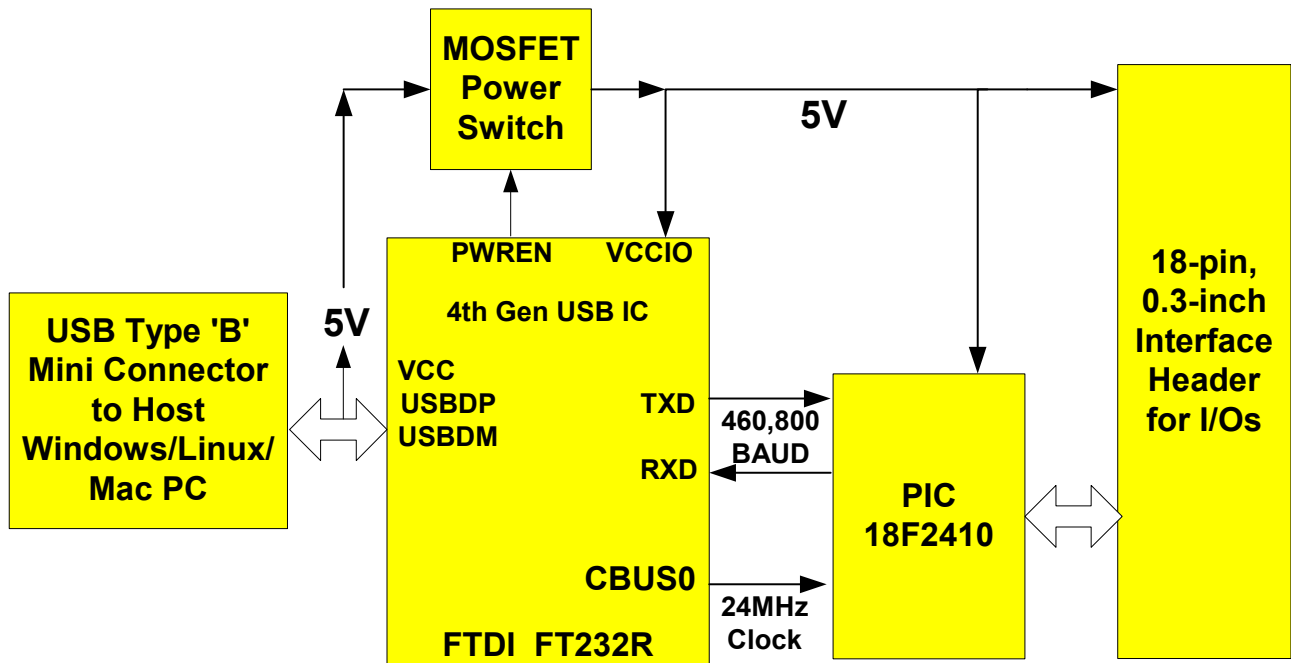

Applications:

- Data Acquisition
- Industrial/Process Control
- Process Monitoring

Features:

- 14 Channels: Digital I/O, Temperature, 8 Configurable For Analog In (0-5 Volts)
- PIC18F2410 Microcontroller
- USB Port Powered
- USB 1.1 and 2.0 Compatible Interface
- Small Footprint: 1.375 x .6 Inch PCB; Standard 18 Pin 0.3-Inch DIP Interface
- Easy to Use with Single-Byte Commands - Can Utilize a Simple Terminal Emulator to Control All Functions

1.0 INTRODUCTION

The DLP-232PC Data Acquisition Module is a low-cost, easy-to-use data acquisition module for measuring voltages, controlling and monitoring processes, and acquiring temperature data. Each of the 14 available channels can be configured for digital I/O, or temperature modes via single-byte commands. Eight of the 14 channels can be configured to measure analog voltages in the range of 0-5 volts. All operational power is taken from the host PC via the USB port.

The mode of each I/O is automatically changed with each command sent. For example, if an I/O is set to Digital Output – High and then the Digital Input Mode is selected, the I/O is first changed to Input Mode and then the high/low state is read and returned to the host.

The programming interface (ICSP) is available for custom firmware development.

2.0 SPECIFICATIONS

The DLP-232PC is a 5-volt system that derives its power from the host USB port. Each channel has the following capabilities:

Digital Output: Set high, or clear to low. (The actual high/low voltage depends upon sink/source current.)

Digital Input: Read the high/low state.

Analog In: (Channels 1-8 only) Read and return the voltage on each I/O pin using a 10-bit A/D: 0-5 volt range.

Temperature: Measure temperature using a digital temperature sensor (purchased separately) in the range of 67 to 257°F (-55 to 125°C).

3.0 ABSOLUTE MAXIMUM RATINGS

Stresses above those listed here may cause permanent damage to the DLP-232PC:

Operating Temperature: 0-70°C

Voltage on I/Os with Respect to Ground: -0.3V to +5.3V

Sink/Source Current on Any I/O: 25mA

4.0 WARNINGS

- Unplug from the host PC before connecting to the DLP-232PC.
- Observe static precautions to prevent damage to the DLP-232PC module.

5.0 USB DRIVERS

USB drivers for the following operating systems are available for download from the DLP Design website:

Windows XP x64	Mac OSX
Windows Server 2003	Mac OS9
Windows 2000	Mac OS8
Windows 98, ME	Linux

These drivers are available for download from the following page: <http://www.dlpdesign.com/DNLD8/>.

NOTE: If using the dual mode drivers from FTDI (CDM2.00.00) and you want to use the Virtual COM Port (VCP) drivers then it may be necessary to disable the D2XX drivers first via Device Manager. Right click on the entry under USB Controllers that appears when the DLP-232PC is connected, select Properties, select the Advanced tab, put a check in the option for "Load VCP" and click OK. Unplug and replug the DLP-232PC and a COM port should appear in Device Manager under Ports (COM & LPT).

6.0 ANALOG CHANNEL SETUP

Channels that are to be used as analog inputs to measure voltage must be properly configured for analog mode. There are 9 possible scenarios for the A/D Setup listed at the end of Table 1 ranging from no analog channels active to all 8 channels active.

Analog channels must be activated in order starting with channel 1. For example, if a systems design requires a single analog channel and 13 digital I/O channels then that analog channel must be channel 1. Refer to the end of Table 1 for more details.

7.0 USING THE DLP-232PC

Simply connect the DLP-232PC to the PC to initiate the loading of drivers. Once the drivers are loaded, the DLP-232PC is ready for use. All commands are single-byte commands.

You can either utilize a simple terminal emulator program, or write your own program in your language of choice. Begin by opening the COM port, set the baud rate to 460800, and send single-byte commands as shown in Table 1. The Ping command can be used to locate the correct COM port used for communicating with the DLP-232PC, or you can look in Device Manager to see which port Windows assigned to the DLP-232PC.

TABLE 1

Channel 1 Commands			
ASCII Character	Hex Value	Description	Return / Comments
1	0x31	Dig Out – High	Nothing returned
Q	0x51	Dig Out – Low	Nothing returned
A	0x41	Digital Input	Returns 0 or 1 (See Note 1)
Z	0x5A	Analog In	Returns measured voltage (See Note 1)
9	0x39	Temperature	Returns current temperature (See Notes 1 and 2)

Channel 2 Commands			
ASCII Character	Hex Value	Description	Return / Comments
2	0x32	Dig Out – High	
W	0x57	Dig Out – Low	
S	0x53	Digital Input	
X	0x58	Analog In	
0	0x30	Temperature	

Channel 3 Commands			
3	0x33	Dig Out – High	
E	0x45	Dig Out – Low	
D	0x44	Digital Input	
C	0x43	Analog In	
-	0x2D	Temperature	

Channel 4 Commands			
4	0x34	Dig Out – High	
R	0x52	Dig Out – Low	
F	0x46	Digital Input	
V	0x56	Analog In	
=	0x3D	Temperature	

Channel 5 Commands			
5	0x35	Dig Out – High	
T	0x54	Dig Out – Low	
G	0x47	Digital Input	
B	0x42	Analog In	
O	0x4F	Temperature	

Channel 6 Commands			
6	0x36	Dig Out – High	
Y	0x59	Dig Out – Low	
H	0x48	Digital Input	
N	0x4E	Analog In	
P	0x50	Temperature	

Channel 7 Commands			
7	0x37	Dig Out – High	
U	0x55	Dig Out – Low	
J	0x4A	Digital Input	
M	0x4D	Analog In	
[0x5B	Temperature	

Channel 8 Commands			
8	0x38	Dig Out – High	
I	0x49	Dig Out – Low	
K	0x4B	Digital Input	
, (Comma)	0x2C	Analog In	
]	0x5D	Temperature	

Channel 9 Commands			
/	0x2F	Dig Out – High	
a	0x61	Dig Out – Low	
b	0x62	Digital Input	
c	0x63	Temperature	

Channel 10 Commands			
d	0x64	Dig Out – High	
e	0x65	Dig Out – Low	
f	0x66	Digital Input	

g	0x67	Temperature	
----------	------	-------------	--

Channel 11 Commands			
h	0x68	Dig Out – High	
i	0x69	Dig Out – Low	
j	0x6a	Digital Input	
k	0x6b	Temperature	

Channel 12 Commands			
l	0x6c	Dig Out – High	
m	0x6d	Dig Out – Low	
n	0x6e	Digital Input	
o	0x6f	Temperature	

Channel 13 Commands			
p	0x70	Dig Out – High	
q	0x71	Dig Out – Low	
r	0x72	Digital Input	
s	0x73	Temperature	

Channel 14 Commands			
t	0x74	Dig Out – High	
&	0x26	Dig Out – Low	
*	0x2A	Digital Input	
(0x28	Temperature	

Setup Commands (Remembered Until Power is Cycled)			
`	0x60	Return ASCII	Default setting; nothing returned (Accent Grave character just left of the 1 key)
\	0x5C	Return Binary	Nothing returned
L	0x4C	Set °F	Default setting; nothing returned
;	0x3B	Set °C	Nothing returned

Ping Command			
'	0x27	Issue Ping	Q (0x51) will be returned if the DLP-232PC is found on the selected port (Apostrophe character just right of the ; key)

A/D Setup			
u	0x75	No Analogs	A/D Converter disabled
v	0x76	CH1 Only	A/D active on channel 1 only
w	0x77	CH1 and CH2	A/D active on channel 1 and 2
x	0x78	CH1,2,3	A/D active on channel 1 through 3
y	0x79	CH1,2,3,4	A/D active on channel 1 through 4
z	0x7A	CH1,2,3,4,5	A/D active on channel 1 through 5
#	0x23	CH1,2,3,4,5,6	A/D active on channel 1 through 6
\$	0x24	CH1 – CH7	A/D active on channel 1 through 7
%	0x25	CH1 – CH8	A/D active on channel 1 through 8

LED Commands			
{	0x7B	LED Off	
}	0x7D	LED On	

Note 1 – Data is returned in either the form of ASCII characters (ex: 1.25V, 78.2°F) or binary (raw data) depending upon the current mode. The power-up default mode is ASCII mode such that data is easily read using a terminal emulator program.

Note 2 – Requires DS18B20 digital temperature sensor (purchased separately). See Section 8.0 of this document for connection details.

8.0 TEMPERATURE

Up to 14 DS18B20 digital temperature sensors can be connected to the DLP-232PC. For best performance, use Cat 5 type computer cable to connect the sensors to the DLP-232PC. Two pairs of wires in the Cat 5 cable are required for the connection. The first pair is for Power (5V) and Ground, and the second pair is designated as Data and Ground. In addition, a pull-up resistor is required for the data line in the range of 1.5K to 4.7K Ohms. Figure 1 shows an example of this connection using I/O Channel 1:

FIGURE 1

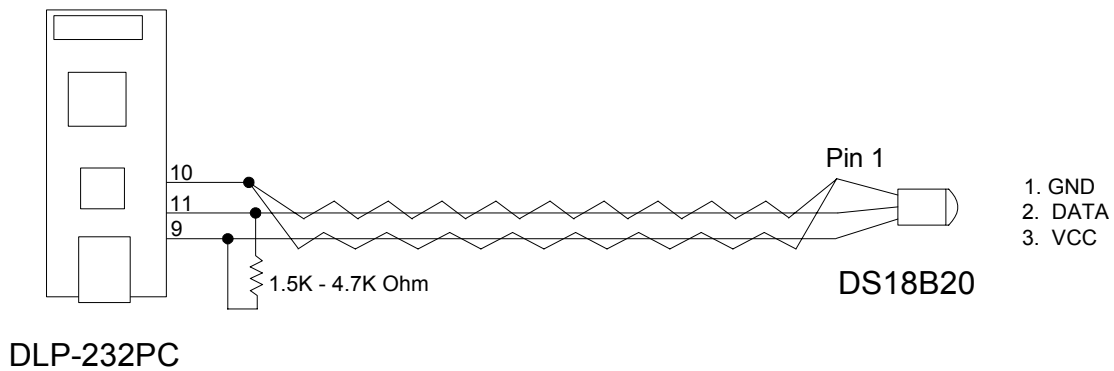

The first time temperature data is requested, a value of 999.99° (0xFF x 2 if in Binary Mode) is returned. Subsequent reads will return valid temperature data if a temperature sensor is properly configured and connected to the specified I/O port. If no sensor is connected, a Temperature command will always return 999.99°.

9.0 RETURN DATA TYPES

By default, the DLP-232PC returns data to the host PC in the form of ASCII text such that it can be easily displayed and read using a simple terminal emulator. Alternatively, data can be returned in binary form requiring the user's host app to calculate the voltage and temperature values. The commands used to set the return data types (0x60 and 0x5C) are shown at the end of Table 1.

10.0 MECHANICAL DIMENSIONS IN INCHES (MM) (PRELIMINARY)

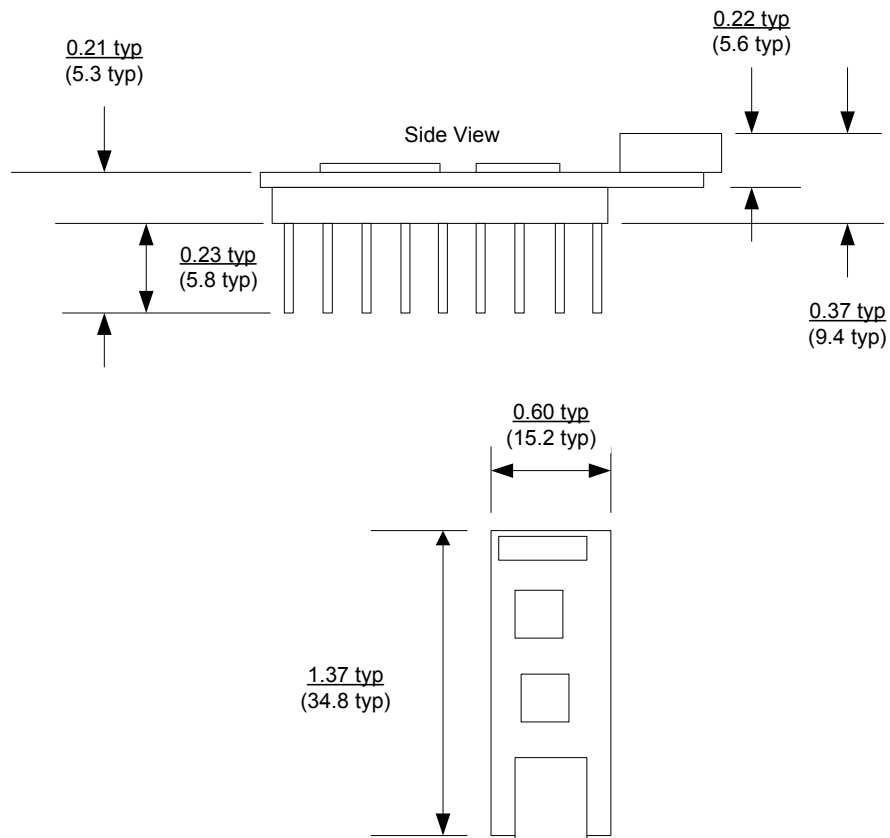

11.0 DISCLAIMER

© DLP Design, Inc., 2007

Neither the whole nor any part of the information contained herein nor the product described in this manual may be adapted or reproduced in any material or electronic form without the prior written consent of the copyright holder.

This product and its documentation are supplied on an as-is basis, and no warranty as to their suitability for any particular purpose is either made or implied. DLP Design, Inc. will not accept any claim for damages whatsoever arising as a result of the use or failure of this product. Your statutory rights are not affected. This product or any variant of it is not intended for use in any medical appliance, device, or system in which the failure of the product might reasonably be expected to result in personal injury.

This document provides preliminary information that may be subject to change without notice.

12.0 CONTACT INFORMATION

DLP Design, Inc.
1605 Roma Lane
Allen, TX 75013
Phone: 469-964-8027
Fax: 415-901-4859
Email Sales: sales@dlpdesign.com
Email Support: support@dlpdesign.com
Website URL: <http://www.dlpdesign.com>

DLP-232PC

Version 1.1

