

# DLP-D

---

## USB-BASED SECURITY DONGLE

### Features:

- Hard-Coded, Unique Serial Number
- USB 1.1 and 2.0 Compatible Interface
- Small Size; Easily Fits on Key Chain

### Applications:

- Access Control
- Copy Protection

## 1.0 INTRODUCTION

The DLP-D Security Dongle is pre-programmed with a unique identification number (Serial Number) that is readable over USB but cannot be altered by any means. Since each serial number is unique, this device provides a way of linking application software to a specific hardware dongle with a high level of security.

## 2.0 USING THE DLP-D

The serial number in the DLP-D Dongle is readable over USB, but it cannot be modified. To read the serial number, USB drivers need to be installed on the PC.

In addition to utilizing the DLP-D Dongle to directly tie hardware to application software, the serial number can be encrypted and then stored in the "User Area" of the DLP-D. The data stored in the integrated EEPROM User Area can contain information in addition to the serial number such as date and time information or the name of the person the device is registered to. The EEPROM User Area is accessible using the USB driver's EEPROM User Area functions: FT\_EE\_UASize, FT\_EE\_UAWrite, and FT\_EE\_UARead.

For example, the serial number can be read and combined with date and time data, perhaps to represent a registration or license expiration date. All of this information can then be encrypted and stored within the EEPROM User Area. Application software can then decrypt this information to determine the date stored in the EEPROM and can compare the decrypted serial number with the unchangeable serial number to confirm that an end user has not modified the EEPROM User Area.

### 3.0 EEPROM USER AREA SIZE

The integrated EEPROM is 1024 bits (128 bytes) in size. The length of the serial number and description strings programmed into the EEPROM determine the amount of the EEPROM User Area available for use by user application software. If these strings are long, there may not be enough User Area available in which to store the encrypted data required. (The USB driver function FT\_EE\_UASize returns the size of the User Area in bytes and can be used to determine if the required space is available before attempting to write data to the EEPROM.)

A remaining User Area of 40 bytes is typical for the DLP-D as shipped from DLP Design.

### 4.0 DEMONSTRATION SOFTWARE

Demonstration software written in both Visual C++ and Visual Basic are available for free download with purchase of the DLP-D Dongle. They demonstrate how to read the serial number, read from and write to the User Area, and determine the User Area's size.

### 5.0 MECHANICAL DIMENSIONS IN INCHES (MM): PRELIMINARY

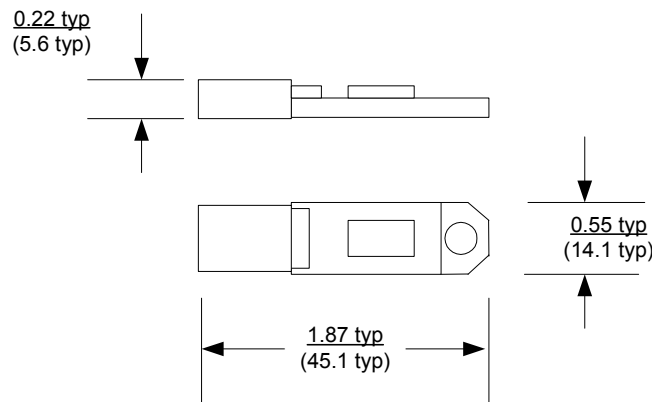

## **7.0 DISCLAIMER**

©DLP Design, Inc., 2006

Neither the whole nor any part of the information contained herein nor the product described in this manual may be adapted or reproduced in any material or electronic form without the prior written consent of the copyright holder.

This product and its documentation are supplied on an as-is basis, and no warranty as to their suitability for any particular purpose is either made or implied. DLP Design, Inc. will not accept any claim for damages whatsoever arising as a result of the use or failure of this product. Your statutory rights are not affected. This product or any variant of it is not intended for use in any medical appliance, device, or system in which the failure of the product might reasonably be expected to result in personal injury.

This document provides preliminary information that may be subject to change without notice.

## **8.0 CONTACT INFORMATION**

DLP Design, Inc.  
1605 Roma Lane  
Allen, TX 75013

Phone: 469-964-8027  
Fax: 415-901-4859

Email Sales: [sales@dlpdesign.com](mailto:sales@dlpdesign.com)  
Email Support: [support@dlpdesign.com](mailto:support@dlpdesign.com)  
Website URL: <http://www.dlpdesign.com>