



**DLP-
USB1232H**
LEAD FREE

HIGH-SPEED USB ADAPTER

The DLP-USB1232H is DLP Design's premier USB-to-UART/FIFO interface module based upon FTDI's fifth-generation USB 2.0 High Speed (480Mb/s) silicon. The DLP-USB1232H is available in a lead-free, RoHS-compliant, compact, 18-pin, 0.1-inch spaced standard DIP footprint.

FEATURES:

The DLP-USB1232H has the capability of being configured in a variety of industry-standard serial or parallel interfaces supporting these features:

- Entire USB protocol handled on the module; no USB-specific firmware programming required
- USB 2.0 High Speed (480Mbits/second) and Full Speed (12Mbits/second) compatible
- Multi-Protocol Synchronous Serial Engine (MP SSE) to simplify synchronous serial protocol (USB to JTAG, I2C, SPI or Bit-Bang) designs
- RS232/RS422/RS485 UART transfer data rate up to 12Mbaud; the RS232 data rate is limited by the external level shifter
- USB-to-parallel FIFO transfer data rate up to 8 Mbyte/sec
- CPU-style FIFO interface mode simplifies CPU interface design
- FTDI's royalty-free Virtual Com Port (VCP) and Direct (D2XX) drivers eliminate the requirement for USB driver development in most cases
- Adjustable receive buffer timeout
- Transmit and receive LED drive signals
- FT245B-style FIFO interface option with bidirectional data bus and a simple four-wire handshake interface
- Asynchronous serial UART interface option with full hardware handshaking and modem interface signals
- Fully assisted hardware or X-On / X-Off software handshaking
- UART interface supports 7/8 bit data, 1/2 stop bits and Odd/Even/Mark/Space/No Parity
- Auto-transmit enable control for RS485 serial applications using the TXDEN Pin
- Operational configuration mode and USB description strings configurable in on-board EEPROM over the USB interface
- Configurable I/O drive strength (4, 8, 12 or 16mA) and slew rate
- Low operating and USB Suspend current
- Supports bus-powered, self-powered and high-power bus-powered USB configurations
- UHCI/OHCI/EHCI host-controller compatible
- USB bulk data transfer mode (512 byte packets in High Speed mode)
- +3.3V I/O interfacing (+5V tolerant)
- Extended -40°C to 85°C industrial operating temperature range

APPLICATION AREAS:

- Upgrading Legacy Peripherals to USB
- Interfacing MCU/PLD/FPGA-Based Designs to USB
- USB to UART (RS232, RS422 or RS485)
- USB to FIFO
- USB to JTAG
- USB to SPI
- USB to I2C
- USB to Bit-Bang
- USB-to-CPU Target Interface (as memory)
- PDA-to-USB Data Transfer
- USB Smart Card Readers
- USB Instrumentation
- USB Industrial Control
- USB MP3 Player Interface
- USB FLASH Card Reader / Writers
- Set Top Box PC-USB Interface
- USB Digital Camera Interface
- USB Bar Code Readers
- USB Audio and Low-Bandwidth Video Data Transfer
- USB Hardware Modems
- USB Wireless Modems

DRIVER SUPPORT:

Royalty-Free Virtual COM Port (VCP) Drivers for:

- Windows 2000, Server 2003, Server 2008
- Windows XP and XP 64-Bit
- Windows Vista and Vista 64-Bit
- Windows XP Embedded
- Windows CE 4.2, 5.0, 5.2 and 6.0
- Mac OS-X
- Linux 2.6.9 or Later

Royalty-Free D2XX Direct Drivers (USB Drivers + DLL S/W Interface) for:

- Windows 2000, Server 2003, Server 2008
- Windows XP and XP 64-Bit
- Windows Vista and Vista 64-Bit
- Windows XP Embedded
- Windows CE 4.2, 5.0, 5.2 and 6.0
- Linux 2.4 or Later and Linux x86_64

The drivers listed above are all available for free download from the DLP Design website www.dlpdesign.com and FTDI website www.ftdichip.com.

Various third-party drivers are also available for other operating systems; see the FTDI website www.ftdichip.com for details.

ABSOLUTE MAXIMUM RATINGS

| | |
|---|---------------------|
| • Storage Temperature | -65°C to +150°C |
| • Ambient Temperature (Power Applied) | -40 to +85°C |
| • VCC Supply Voltage | -0.5V to +6.00V |
| • DC Input Voltage: Inputs | -0.5V to VCC + 0.5V |
| • DC Input Voltage: High-Impedance Bidirectionals | -0.5V to VCC + 0.5V |
| • DC Output Current: Outputs | 16mA |

D.C. CHARACTERISTICS (AMBIENT TEMPERATURE: -40 TO 85°C)

| | |
|----------------------------------|-------------------------|
| • VCC Operating-Supply Voltage | 4.0 - 5.5V |
| • VCCIO Operating-Supply Voltage | 4.0 - 5.5V |
| • Operating Supply Current | 75mA (Normal Operation) |
| • Operating Supply Current | 500uA USB Suspend |

1.0 GENERAL DESCRIPTION

The DLP-USB1232H USB 2.0 High Speed (480Mb/s) to UART/FIFO uses FTDI's fifth-generation USB silicon. It has the capability of being configured in a variety of industry-standard serial or parallel interfaces. The DLP-USB1232H can be configured for UART, FIFO, JTAG, SPI, I2C or Bit-Bang mode. In addition to these, the DLP-USB1232H supports a CPU interface FIFO mode.

Refer to the FT2232H datasheet for additional detail on how to set up and use the supported modes www.dlpdesign.com/usb/ds_ft2232h.pdf.

2.0 PIN DESCRIPTIONS

This section describes the operation of the DLP-USB1232H pins. The function of the I/O pins is determined by the configuration that is stored in the EEPROM connected to the FT2232H USB IC.

The following table details the function of each pin for the specified mode. Note that the convention used throughout this document for active low signals is the signal name followed by a "#". Pins marked "***" default to tri-stated inputs with an internal 75K-Ohm (approx) pull-up resistor to VCCIO (3.3V).

| DLP-USB1232H | | | | | | | | |
|--------------|----------|---------------------------------------|---------------|----------|----------------|---------------|--------|------------|
| PIN | | PIN FUNCTIONS FOR EACH SUPPORTED MODE | | | | | | |
| Pin # | Pin Name | ASYNC Serial (RS232) | 245 FIFO SYNC | 245 FIFO | ASYNC Bit-Bang | SYNC Bit-Bang | MPSSE | CPU Target |
| CHANNEL A | | | | | | | | |
| 18 | ADBUS0 | TXD | D0 | D0 | D0 | D0 | TCK/SK | D0 |
| 16 | ADBUS1 | RXD | D1 | D1 | D1 | D1 | TDI/DO | D1 |
| 2 | ADBUS2 | RTS# | D2 | D2 | D2 | D2 | TDO/DI | D2 |
| 5 | ADBUS3 | CTS# | D3 | D3 | D3 | D3 | TMS/CS | D3 |
| 17 | ADBUS4 | DTR# | D4 | D4 | D4 | D4 | GPIOL0 | D4 |
| 4 | ADBUS5 | DSR# | D5 | D5 | D5 | D5 | GPIOL1 | D5 |
| 13 | ADBUS6 | DCD# | D6 | D6 | D6 | D6 | GPIOL2 | D6 |
| 3 | ADBUS7 | RI# | D7 | D7 | D7 | D7 | GPIOL3 | D7 |
| 15 | ACBUS0 | TXDEN | RXF# | RXF# | ** | ** | GPIOH0 | CS# |
| 14 | ACBUS1 | | TXE# | TXE# | WRSTB# | WRSTB# | GPIOH1 | A0 |
| 11 | ACBUS2 | | RD# | RD# | RDSTB# | RDSTB# | GPIOH2 | RD# |
| 12 | ACBUS3 | TXLED# | WR# | WR# | ** | ** | GPIOH3 | WR# |
| 7 | ACBUS4 | RXLED# | SIWUA | SIWUA | SIWUA | SIWUA | GPIOH4 | SIWUA |

**These pins default to tri-stated inputs with an internal 75K Ohm (approx) pull-up resistor to VCCIO.

3.0 TIMING DIAGRAMS - 245 FIFO MODE

| TIME | DESCRIPTION | MIN | MAX | UNIT |
|------|---|---------|-----|------|
| T1 | RD# Active Pulse Width | 50 | - | nS |
| T2 | RD# to RD# Pre-Charge | T5 + T6 | - | nS |
| T3 | RD# Active to Valid Data* | 20 | 50 | nS |
| T4 | Valid Data Hold Time from RD# Inactive* | 0 | - | nS |
| T5 | RD# Inactive to RXF# Output Active | 0 | 25 | nS |
| T6 | RXF# Inactive After RD Cycle | 33 | 67 | nS |
| T7 | WR Active Pulse Width | 10 | - | nS |
| T8 | WR to WR Pre-Charge Time | 50 | - | nS |
| T9 | Valid Data Setup to WR Falling Edge* | 20 | - | nS |
| T10 | Valid Data Hold Time from WR Inactive* | 10 | - | nS |
| T11 | WR Inactive to TXE# | 10 | 25 | nS |
| T12 | TXE# Inactive After WR Cycle | 49 | 84 | nS |

*Load = 30pF

4.0 APPLICATION NOTES

USB devices transfer data in packets. If data is to be sent from the PC, a packet is built up by the application program and is sent via the device driver to the USB scheduler. This scheduler adds a request to the list of tasks that the USB host controller will perform. This will typically take at least 1 millisecond to execute because it will not pick up the new request until the next USB frame (the frame period is 1 millisecond). Therefore, there is sizeable overhead

(depending upon your required throughput) associated with moving data from the application to the USB device. If data is sent one byte at a time by an application, this will severely limit the overall throughput of the system.

It must be stressed that in order to achieve maximum throughput, application programs should send or receive data using buffers and not individual characters.

5.0 DRIVER SOFTWARE

FTDI's VCP (Virtual COM Port) USB driver files are provided royalty free on the condition that they are only used with designs incorporating an FTDI device (i.e. the FT2232H and DLP-USB1232H). The latest version of the drivers can be downloaded from either www.dlpdesign.com or www.ftdichip.com.

The CDM driver download file is a combined set of drivers for the Windows operating system that contains both the VCP and D2XX driver versions. To download, simply unzip the file to a folder on your PC. (The drivers can coexist on the same floppy disk or folder since the INF files determine which set of drivers to load for each operating-system version.) Once loaded, the VCP drivers will allow your application software—running on the host PC—to communicate with the DLP-USB1232H as though it were connected to a COM (RS-232) port.

In addition to VCP drivers, FTDI's D2XX direct drivers for Windows offer an alternative solution to the VCP drivers that allow application software to interface with the FT2232H device using a DLL instead of a Virtual COM Port. The architecture of the D2XX drivers consists of a Windows WDM driver that communicates with the FT2232H device via the Windows USB stack and a DLL that interfaces with the application software (written in VC++, C++ Builder, Delphi, VB, etc.) to the WDM driver.

The D2XX direct drivers add support for simultaneous access and control of multiple DLP-USB1232H devices. The extended open function (FT_OpenEx) allows the device to be opened either by its product description or serial number; both of which can be programmed to be unique. The list devices function (FT_ListDevices) allows the application software to determine which devices are currently available for use, again by either product description or serial number.

Download FTDI Application Notes AN_103 and AN_104 for detailed instructions on how to install the drivers on XP and Vista platforms.

6.0 EEPROM WRITE UTILITY

The DLP-USB1232H provides its users with the option to accept manufacturer-specific information that is written into EEPROM memory. Parameters that can be programmed include the VID and PID identifiers, the manufacturer's product string and a serial number.

MPROG is the latest EEPROM programming utility for the FT2232H device. You must install the latest release of the CDM drivers in order to run this application. If you have CDM drivers installed on the PC that is to perform the EEPROM write process, you can run MPROG and update the EEPROM contents with either mode (VCP or D2XX) active.

7.0 QUICK START GUIDE

This guide requires the use of a Windows XP/Vista PC that is equipped with a USB port.

1. Download the latest CDM device drivers from either www.dlpdesign.com or www.ftdichip.com. Unzip the drivers into a folder on the hard drive.
2. Connect the DLP-USB1232H module to the PC via a USB 'A' to mini-B cable. This action initiates loading of the USB drivers. When prompted, select the folder where the device drivers were stored in Step 1. Windows will then complete the installation of the device drivers for the DLP-USB1232H module. The next time the DLP-USB1232H module is attached, the host PC will immediately load the correct drivers without any prompting. Reboot the PC if prompted to do so.

At this point, the DLP-USB1232H is ready for use. Note that if the DLP-USB1232H is configured for 245 FIFO mode and that it will appear non-responsive if data sent from the host PC is not read by an attached microcontroller, microprocessor, DSP, FPGA, ASIC, etc.

8.0 PINOUT DESCRIPTIONS

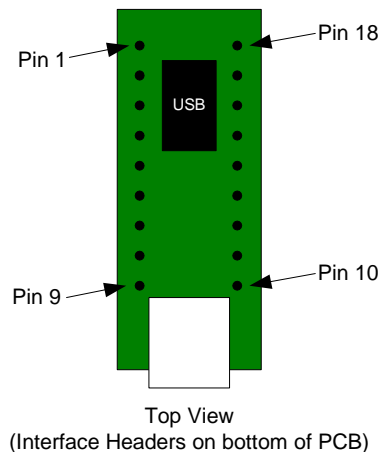

| PIN # | PARALLEL SIGNAL USAGE DESCRIPTIONS |
|-------|---|
| 1 | GROUND |
| 2 | DB2 - FIFO Data Bus Bit 2 |
| 3 | DB7 - FIFO Data Bus Bit 7 |
| 4 | DB5 - FIFO Data Bus Bit 5 |
| 5 | DB3 - FIFO Data Bus Bit 3 |
| 6 | <p>PWREN - Active low power-enable output.</p> <ul style="list-style-type: none"> • PWREN# = 0: Normal operation. • PWREN# = 1: USB Suspend Mode or device has not been configured. This can be used by external circuitry to power down logic when the device is in USB Suspend or has not been configured. |

| | |
|----|--|
| 7 | SIWUA -The Send Immediate / WakeUp signal combines two functions on a single pin. If USB is in Suspend Mode (PWREN# = 1) and remote wakeup is enabled in the EEPROM, strobing this pin low will cause the device to request a resume on the USB bus. Normally, this can be used to wake up the host PC. During normal operation (PWREN# = 0), if this pin is strobed low, any data in the device TX buffer will be sent out over USB on the next Bulk-IN request from the drivers regardless of the pending packet size. This can be used to optimize USB transfer speed for some applications. (Tie this pin to VCCIO if not used.) |
| 8 | EXTVCC - Use for applying main power (4.5-5.25 volts) to the module. Connect to PORTVCC (Pin 9) if the module is to be powered by the USB port (typical configuration). |
| 9 | PORTVCC - Power from the USB port. Connect to EXTVCC (Pin 8) if the module is to be powered by the USB port (typical configuration). 500mA is the maximum current available to the USB adapter and target electronics if the USB device is configured for high power. |
| 10 | GROUND |
| 11 | RD# - When pulled low, RD# takes the eight data lines from a high-impedance state to the current byte in the FIFO's buffer. Taking RD# high returns the data pins to a high-impedance state and prepares the next byte (if available) in the FIFO to be read. |
| 12 | WR - When taken from a high to a low state, WR reads the eight data lines and writes the byte into the FIFO's transmit buffer. Data written to the transmit buffer is sent to the host PC within the TX buffer timeout value (default 16mS) and placed in the buffer that was created when the USB port was opened. The FT245R allows the TX buffer timeout value to be reprogrammed to a value between 1 and 255mS. |
| 13 | DB6 - FIFO Data Bus Bit 6. |
| 14 | TXE# - When high, do not write data into the FIFO. When low, data can be written into the FIFO by strobing WR high, then low. During reset this signal pin is tri-state. Data is latched into the FIFO on the falling edge of the WR pin. |
| 15 | RXF# - When low, at least 1 byte is present in the FIFO's receive buffer and is ready to be read with RD#. RXF# goes high when the receive buffer is empty. During reset this signal pin is tri-state. If the Remote Wakeup option is enabled in the internal EEPROM during USB Suspend Mode (PWREN#=1), RXF# becomes an input. This can be used to wake up the USB host from Suspend Mode by strobing this pin low for a minimum of 20ms which will cause the device to request a resume on the USB bus. |
| 16 | DB1 - FIFO Data Bus Bit 1. |
| 17 | DB4 - FIFO Data Bus Bit 4. |
| 18 | DB0 - FIFO Data Bus Bit 0. |

| PIN # | SERIAL SIGNAL USAGE DESCRIPTIONS |
|-------|---|
| 1 | GROUND |
| 2 | RTS - Request to Send Control Output/Handshake Signal |
| 3 | RI - Ring Indicator Control Input. When remote wake-up is enabled in the internal EEPROM taking RI# low (20ms active low pulse), this can be used to resume the PC USB host controller from Suspend. |
| 4 | DSR - Data Set Ready Control Input/Handshake Signal |
| 5 | CTS - Clear To Send Control Input/Handshake Signal |

| | |
|----|--|
| 6 | PWREN - Active low power-enable output. <ul style="list-style-type: none"> • PWREN# = 0: Normal operation. • PWREN# = 1: USB Suspend Mode or device has not been configured. This can be used by external circuitry to power down logic the when device is in USB Suspend or has not been configured. |
| 7 | RXLED - Receive signaling output. Pulses low when receiving data via USB. This should be connected to an LED. |
| 8 | EXTVCC - Use for applying main power (4.5-5.25 volts) to the module. Connect to PORTVCC (Pin 9) if the module is to be powered by the USB port (typical configuration). |
| 9 | PORTVCC - Power from the USB port. Connect to EXTVCC (Pin 8) if the module is to be powered by the USB port (typical configuration). 500mA is the maximum current available to the USB adapter and target electronics if the USB device is configured for high power. |
| 10 | GROUND |
| 11 | Not utilized in this mode. |
| 12 | TXLED# - Transmit signaling output. Pulses low when transmitting data via USB. This should be connected to an LED. |
| 13 | DCD# - Data Carrier Detect Control Input. |
| 14 | Not utilized in this mode. |
| 15 | TXDEN - (TTL level) For use with RS485-level converters. |
| 16 | RXD - Receiving Asynchronous Data Input. |
| 17 | DTR# - Data Terminal Ready Control Output/Handshake Signal. |
| 18 | TXD - Transmit Asynchronous Data Output. |

9.0 DEVICE CONFIGURATION EXAMPLES

USB Bus-Powered and Self-Powered Configurations

Figure 1.

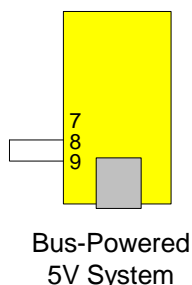

The figure above illustrates a typical USB bus-powered configuration. A USB bus-powered device gets its power from the USB bus.

Figure 2.

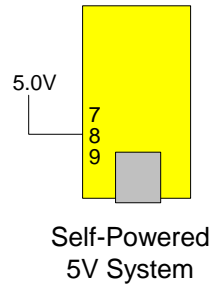

Figure 2 illustrates a typical USB self-powered configuration. A USB self-powered device gets its power from its own power supply and does not draw current from the USB bus.

Figure 3.

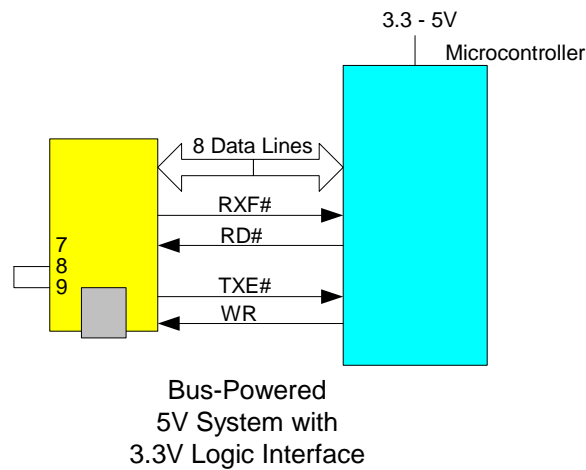

Figure 3 shows how to configure the DLP-USB1232H to interface with a microcontroller via the parallel 245 FIFO interface mode. In this example, the target electronics can operate at 3.3 - 5 volts since the DLP-USB1232H interface I/O pins are 5-volt tolerant.

Figure 4.

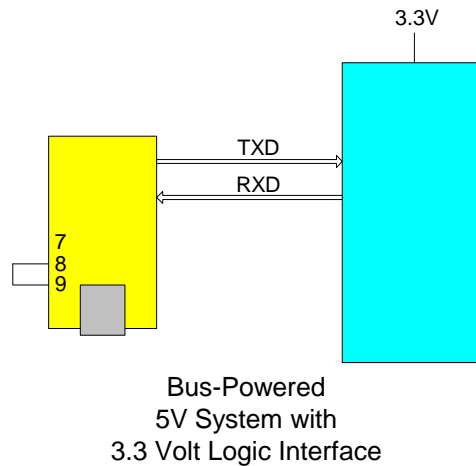

Figure 4 shows how to configure the DLP-USB1232H to interface with a 3.3V logic device via the ASYNC serial mode. In this example, the target electronics provide the 3.3 volts to power the microcontroller.

10.0 BUS-POWERED CIRCUIT WITH POWER CONTROL

USB bus-powered circuits need to be able to power down in USB Suspend Mode in order to meet the Suspend current requirement (including external logic):

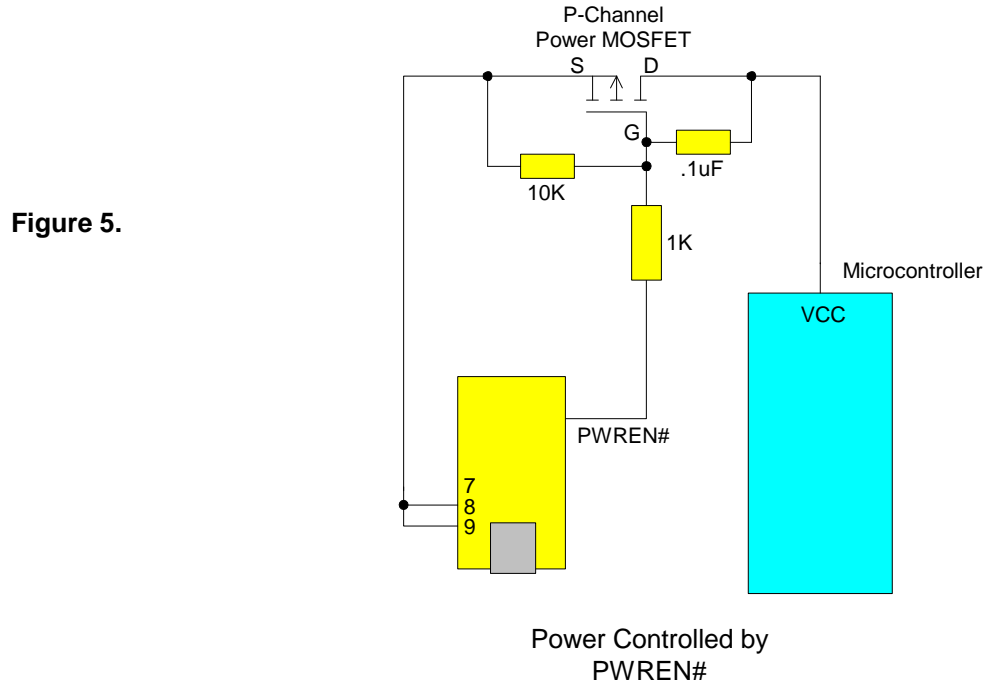
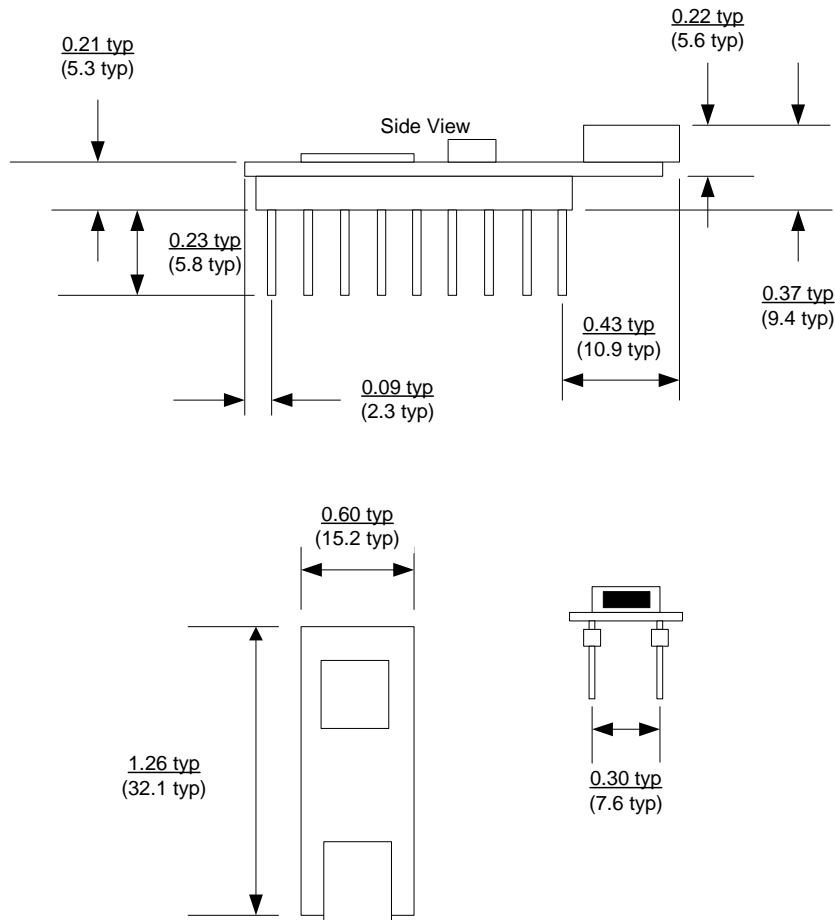

Figure 5 shows how to use a discrete P-Channel MOSFET to control the power to external logic circuits. This “soft-start” circuit accommodates designs that draw more than 100mA at power up.

11.0 MECHANICAL DRAWINGS (PRELIMINARY) INCHES (MILLIMETERS) UNLESS OTHERWISE NOTED



12.0 DISCLAIMER

© DLP Design, Inc., 2009

Neither the whole nor any part of the information contained herein nor the product described in this manual may be adapted or reproduced in any material or electronic form without the prior written consent of the copyright holder.

This product and its documentation are supplied on an as-is basis, and no warranty as to their suitability for any particular purpose is either made or implied. DLP Design, Inc. will not accept any claim for damages whatsoever arising as a result of the use or failure of this product. Your statutory rights are not affected. This product or any variant of it is not intended for use in any medical appliance, device or system in which the failure of the product might reasonably be expected to result in personal injury.

This document provides preliminary information that may be subject to change without notice.

13.0 CONTACT INFORMATION

DLP Design, Inc.
1605 Roma Lane
Allen, TX 75013

Phone: 469-964-8027
Fax: 415-901-4859

Email Sales: sales@dlpdesign.com
Email Support: support@dlpdesign.com
Website URL: <http://www.dlpdesign.com>



