



Future Technology Devices International Ltd.

Application Note AN_137

Vinculum-II IO Cell Description

Document Reference No.: FT_000232

Version 1.0

Issue Date: 2010-02-19

The purpose of this document is to describe the IO Cell type used in the Vinculum-II devices interface.

TABLE OF CONTENTS

1	Introduction.....	3
2	The IO Cell.....	4
3	Summary	5
4	Contact Information.....	6
	Appendix A– Revision History.....	8

1 Introduction

The Vinculum VNC2 device is FTDI's 2nd generation USB host solution device and expands on the capabilities of the VNC1L. The device is supplied in 6 different packages. There are 32 pin QFN and LQFP packages, 48 pin QFN and LQFP packages and 64 pin QFN and LQFP packages.

The 32 pin packages have 12 IO pins, the 48 pin package has 28 IO pins and the 64 pin package has 44 IO pins.

Each of the IO pins interface to the external logic and may be defined as an input or an output. All IO pins default to an input following a reset.

Following a reset, the IO MUX module within VNC2 can be enabled to set pin function and direction. The actual definition of the pin function and direction is controlled by the firmware.

2 The IO Cell

The IO cell is an LVTTTL 3V3 (5V tolerant IO Cell).

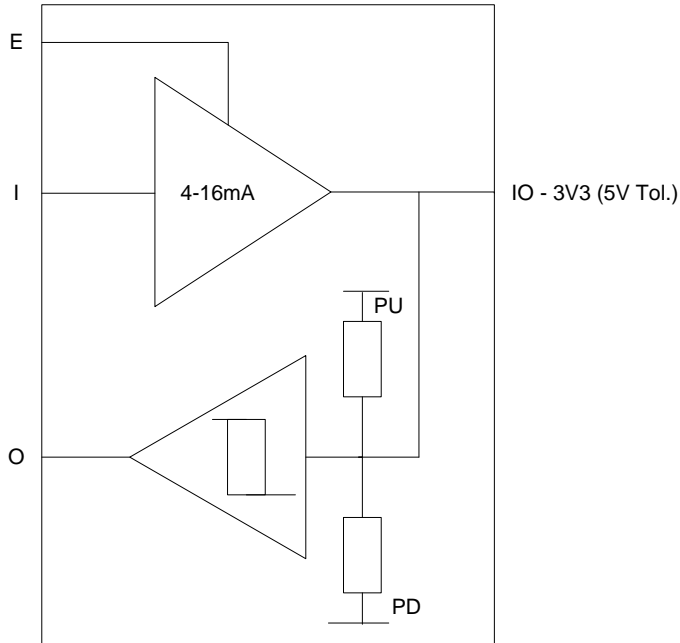

Figure 1: IO Cell

LVTTTL	Low Voltage Transistor Transistor Logic
E	Enable to enable the output stage
I	Input
O	Output
IO	Input/Output
PU	Pull up resistor (75kOhm) option
PD	Pull down resistor (75kOhm) option

Figure 2: Symbol Table

The IO drive strength of the output stage may be configured to be either 4mA, 8mA, 12mA or 16mA. This is controlled by a register setting which is set within the firmware. The default is 4mA.

The input may be configured to use a pull up, pull down resistor or have no termination at all. The value of the pull up / pull down is 75kOhm. The default is to disable the pull up and pull down resistors.

There is also the capability to control the slew rate – fast or slow. The default is set to fast.

An additional option is the capability of configuring each IO input as a normal input or a Schmitt trigger input. The default is to disable the Schmitt trigger capability.

3 Summary

Although designed for use in a 3V3 system, the IO is tolerant of 5V inputs and can be used to interface to 3V3 or 5V systems. With the configurability of the cell it is not necessary to use external pull up or pull down resistors to realise a design which will result in a smaller bill of materials and less board space on the PCB.

4 Contact Information

Head Office – Glasgow, UK

Future Technology Devices International Limited
Unit 1, 2 Seaward Place, Centurion Business Park
Glasgow G41 1HH
United Kingdom

Tel: +44 (0) 141 429 2777
Fax: +44 (0) 141 429 2758

E-mail (Sales) sales1@ftdichip.com
E-mail (Support) support1@ftdichip.com
E-mail (General Enquiries) admin1@ftdichip.com
Web Site URL <http://www.ftdichip.com>
Web Shop URL <http://www.ftdichip.com>

Branch Office – Taipei, Taiwan

Future Technology Devices International Limited (Taiwan)
2F, No 516, Sec. 1 NeiHu Road
Taipei 114
Taiwan, R.O.C.
Tel: +886 (0) 2 8797 1330
Fax: +886 (0) 2 8751 9737

E-mail (Sales) tw.sales1@ftdichip.com
E-mail (Support) tw.support1@ftdichip.com
E-mail (General Enquiries) tw.admin1@ftdichip.com
Web Site URL <http://www.ftdichip.com>

Branch Office – Hillsboro, Oregon, USA

Future Technology Devices International Limited (USA)
7235 NW Evergreen Parkway, Suite 600
Hillsboro, OR 97123-5803
USA
Tel: +1 (503) 547 0988
Fax: +1 (503) 547 0987

E-Mail (Sales) us.sales@ftdichip.com
E-Mail (Support) us.admin@ftdichip.com
Web Site URL <http://www.ftdichip.com>

Branch Office – Shanghai, China

Future Technology Devices International Limited (China)
Room 408, 317 Xianxia Road,
ChangNing District,
ShangHai, China

Tel: +86 (21) 62351596
Fax: +86(21) 62351595

E-Mail (Sales): cn.sales@ftdichip.com
E-Mail (Support): cn.support@ftdichip.com
E-Mail (General Enquiries): cn.admin1@ftdichip.com
Web Site URL: <http://www.ftdichip.com>

Distributor and Sales Representatives

Please visit the Sales Network page of the FTDI Web site for the contact details of our distributor(s) and sales representative(s) in your country.

Neither the whole nor any part of the information contained in, or the product described in this manual, may be adapted or reproduced in any material or electronic form without the prior written consent of the copyright holder. This product and its documentation are supplied on an as-is basis and no warranty as to their suitability for any particular purpose is either made or implied. Future Technology Devices International Ltd will not accept any claim for damages howsoever arising as a result of use or failure of this product. Your statutory rights are not affected. This product or any variant of it is not intended for use in any medical appliance, device or system in which the failure of the product might reasonably be expected to result in personal injury. This document provides preliminary information that may be subject to change without notice. No freedom to use patents or other intellectual property rights is implied by the publication of this document. Future Technology Devices International Ltd, Unit 1, 2 Seaward Place, Centurion Business Park, Glasgow G41 1HH United Kingdom. Scotland Registered Number: SC136640

Appendix A– Revision History

Version Draft	First Draft	01/02/2010
Version 1.0	First release	19/02/2010