

# EMC TEST REPORT

According to

- 1) EN 55022: 1998+A1: 2000+A2:2003
- 2) EN 61000-3-2: 2000
- 3) EN 61000-3-3: 1995+A1: 2001
- 4) EN 55024: 1998+A1: 2001+A2:2003  
EN 61000-4-2: 1995+A1: 1998+A2:2001 / EN 61000-4-3: 2002+A1:2002  
EN 61000-4-4: 1995+A2: 2001 / EN 61000-4-5: 1995+A1: 2001  
EN 61000-4-6: 1996+A1: 2001 / EN 61000-4-8: 1993+A1: 2001  
EN 61000-4-11: 1994+A1: 2001

EUT Name : Chipi

Model No. : UC232R

Applicant : FUTURE TECHNOLOGY DEVICES INTERNATIONAL LTD.

Address : 373 SCOTLAND ST.,GLASGOW G58QB SCOTLAND U.K.

Test Engineer : MICK CHOU

Reviewed by : BARRY MA

Issued Date: : SEP. 26, 2005

- The test report shall not be reproduced except in full, without the written approval of the laboratory.
- The report can't be used by the client to claim product endorsement by PEP Testing Laboratory.
- This report is only for the equipment which described in page 8.

# PEP Testing Laboratory

12-3Fl, No. 27-1, Lane 169, Kang-Ning St., Hsi-Chih,

Taipei Hsien, Taiwan, R. O. C.

TEL: 886-2-26922097 FAX: 886-2-26956236

REPORT NO. : E940698

## TABLE OF CONTENTS

<b>1. General</b>	5
1.1 General Information	
1.2 Place of Measurement	
1.3 Test Standards	
<b>2. Product Information</b>	7
<b>3. EUT Description and Test Conclusion</b>	8
<b>4. Modification(s)</b>	9
<b>5. Test Software Used</b>	9
<b>6. Support Equipment Used</b>	10
<b>7. EN 55022 Conducted Disturbance Test</b>	12
7.1 Test Limits	
7.2 Test Setup Photos	
7.3 Test Data	
<b>8. EN 55022 Radiated Disturbance Test</b>	17
8.1 Test Description	
8.2 Test Setup	
8.3 Test Limits	
8.4 Test Setup photos	
8.5 Test Data	
<b>9. EN 61000-3-2 Harmonic Current Test</b>	23
9.1 Test Description	
9.2 Flow-chart for determining Conformity	
9.3 Test Setup	
9.4 Test Limits	
9.5 Test Setup photo	
9.6 Test Data	

# PEP Testing Laboratory

12-3Fl, No. 27-1, Lane 169, Kang-Ning St., Hsi-Chih,

Taipei Hsien, Taiwan, R. O. C.

TEL: 886-2-26922097 FAX: 886-2-26956236

REPORT NO. : E940698

<b>10. EN 61000-3-3 Voltage Fluctuations Test</b>	30
10.1 Test Description	
10.2 Test Limits	
10.3 Test Setup Photo	
10.4 Test Data	
<b>11. EN 61000-4-2 Electrostatic Discharge Test</b>	34
11.1 Test Description	
11.2 Test Setup	
11.3 Test Limits	
11.4 Discharge Test Drawing	
11.5 Test Data	
<b>12. EN 61000-4-3 Radio-Frequency Electromagnetic Field Test</b>	42
12.1 Test Description	
12.2 Test Block Diagram	
12.3 Test Limits	
12.4 Test Setup Photo	
<b>13. EN 61000-4-4 Fast Transient Burst Test</b>	47
13.1 Test Description	
13.2 Test Setup	
13.3 Test Limits	
13.4 Test Setup Photo	
13.5 Test Data	
<b>14. EN 61000-4-5 Surge Immunity Test</b>	53
14.1 Test Description	
14.2 Test Setup	
14.3 Test Limits	
14.4 Test Setup Photo	
14.5 Test Data	

# PEP Testing Laboratory

12-3Fl, No. 27-1, Lane 169, Kang-Ning St., Hsi-Chih,

Taipei Hsien, Taiwan, R. O. C.

TEL: 886-2-26922097 FAX: 886-2-26956236

REPORT NO. : E940698

<b>15. EN 61000-4-6 Immunity To Conducted Disturbances, Induced By</b>	59
<b>Radio-Frequency Fields</b>	
15.1 Test Description	
15.2 Test Setup	
15.3 Test Limits	
15.4 Test Setup Photo	
15.5 Test Data	
<b>16. EN 61000-4-8 Power Frequency Magnetic Field Immunity Test</b>	65
16.1 Test Description	
16.2 Test Setup	
16.3 Test Limits	
16.4 Test Setup Photos	
<b>17. EN 61000-4-11 Voltage Dips, Short Interruptions and Voltage Variations</b>	70
<b>Immunity Tests</b>	
17.1 Test Description	
17.2 Test Setup	
17.3 Test Limits	
17.4 Test Setup Photo	
17.5 Test Data	
<b>18. Labelling Requirement, Warning</b>	75
<b>19. The List of Test Instruments</b>	76
<b>20. EUT Photos</b>	78

# PEP Testing Laboratory

12-3Fl, No. 27-1, Lane 169, Kang-Ning St., Hsi-Chih,

Taipei Hsien, Taiwan, R. O. C.

TEL: 886-2-26922097 FAX: 886-2-26956236

REPORT NO. : E940698

## 1. General

### 1.1 General Information :

Applicant : FUTURE TECHNOLOGY DEVICES INTERNATIONAL LTD.

Address : 373 SCOTLAND ST.,GLASGOW G58QB SCOTLAND U.K.

Manufacturer : FUTURE TECHNOLOGY DEVICES INTERNATIONAL LTD.

Address : 373 SCOTLAND ST.,GLASGOW G58QB SCOTLAND U.K.

Measurement Procedure : EN55022

Measurement Uncertainty :

The uncertainty of the testing result is given as below. The method of uncertainty

Calculation is provided in PEP Testing Lab document No. QP-T-28-B & QP-T-27-B

Frequency ( MHz )	0.15 ~ 30	30 ~ 1000
Expanded Uncertainty $\mu_c$	1.4 (dB)	2.84 (dB)

※ 95% Confidence Level; K=2

### 1.2 Place of Measurement

#### **PEP TESTING LABORATORY**

*12-3Fl, No. 27-1, Lane 169, Kang-Ning St., Hsi-Chih,  
Taipei Hsien, Taiwan, R. O. C.*

*TEL : 886-2-26922097 FAX : 886-2-26956236*

NVLAP LAB CODE 200097-0

FCC Registration No. : 90868

NEMKO Aut. No. : ELA133

BSMI Aut. No. : SL2-IN-E-11

VCCI Registration No. : C-493/R-477

### 1.3 Test Standards

Tested for compliance with:

- EN 55022:1998** - Information Technology Equipment – Radio disturbance characteristics - Limits and methods of measurement
- +A1: 2000+A2: 2003**
- EN 61000-3-2: 2000** - Electromagnetic compatibility (EMC) Part 3-2: Limits – Limits for harmonic current emissions (equipment input Current up to and including 16A per phase
- EN 61000-3-3: 1995** - Electromagnetic compatibility (EMC) Part 3-2: Limits – Limitation of voltage fluctuations and flicker in low-voltage supply systems for equipment with rated current up to 16A
- +A1: 2001**
- EN 55024:1998** - Information technology equipment – Immunity characteristics Limits and methods of measurement
- +A1: 2001+A2: 2003**
- EN 61000-4-2: 1995** - Electromagnetic compatibility (EMC) Part 4: Testing and measurement techniques, Section 2: Electrostatic discharge immunity test Basic EMC Publication
- +A1: 1998+A2: 2001**
- EN 61000-4-3: 2002** - Electromagnetic compatibility (EMC) Part 4: Testing and measurement techniques, Section 3: Radiated, radio-Frequency, electromagnetic field immunity test
- +A1: 2002**
- EN 61000-4-4: 1995** - Electromagnetic compatibility (EMC) Part 4: Testing and measurement techniques, Section 4: Electrical fast transient / Burst immunity test Basic EMC publication
- +A2: 2001**
- EN 61000-4-5: 1995** - Electromagnetic compatibility (EMC) Part 4: Testing and measurement techniques, Section 5: Surge immunity test (includes corrigendum: 1995)
- +A1: 2001**
- EN 61000-4-6: 1996** - Electromagnetic compatibility (EMC) Part 4: Testing and measurement techniques, Section 6: Immunity to conducted disturbances, induced by radio-frequency fields
- +A1: 2001**
- EN 61000-4-8: 1993** - Electromagnetic compatibility (EMC) Part 4: Testing and measurement techniques, Section 8: Power frequency magnetic field immunity test Basic EMC publication
- +A1: 2001**
- EN 61000-4-11: 1994** - Electromagnetic compatibility (EMC) Part 4: Testing and measurement techniques, Section 11: Voltage dips, short interruptions and voltage variations immunity tests
- +A1: 2001**

## PEP Testing Laboratory

12-3Fl, No. 27-1, Lane 169, Kang-Ning St., Hsi-Chih,

Taipei Hsien, Taiwan, R. O. C.

TEL: 886-2-26922097 FAX: 886-2-26956236

REPORT NO. : E940698

### 2. Product Information

- a. **EUT Name:** Chipi
- b. **Model No. :** UC232R
- c. **CPU Type :** N/A
- d. **CPU Frequency :** N/A
- e. **Crystal/Oscillator(s) :** N/A
- f. **Chassis Used :** N/A
- g. **Port/Connector(s) :** USB Connector × 1, RS-232 Connector × 1
- h. **Power Rating :** DC 5V ----- from PC
- i. **Condition of the EUT :**  Prototype Sample  Engineering Sample  
 Production Sample
- j. **Test Item Receipt Date :** SEP. 12, 2005
- k. **Date(s) of performance of test :** SEP. 12, 2005 – SEP. 26, 2005

### **3. EUT Description and Test Conclusion**

The equipment under test (EUT) is Chipi model UC232R. The EUT is data cable designed for the application of communicating USB and RS232 interface devices. 5Vdc via USB interface is required to operate EUT. For more detail specification about the EUT, please refer to the user's manual.

Test method: According to the major function designed, the EUT configuration was set up by the following steps for test:

(A) Connect EUT RS232 connector to modem.

(B) Connect EUT USB connector to PC USB port.

All corresponding peripherals to PC I/O ports and EUT were set to proceed with test. The test was carried out on EUT operational condition and the worst-case test result was recorded and provided in this report.

Conducted emission test:

The system was setup with the EMI diagnostic software running. The power line conducted EMI tests were run on the line and neutral conductors of the power cord and the results were recorded. The effect of varying the position of the interface cables has been investigated to find the worst-case configuration that produces maximum emission.

At the frequencies where the peak values of the emission exceeded the quasi-peak limit, the emissions were also measured with the quasi-peak detectors. The average detector also measured the emission either (A) quasi-peak values were under quasi-peak limit but exceeded average limit, or (B) peak values were under quasi-peak limit but exceeded average limit.

Radiated emission test:

The maximum readings were found by varying the height of antenna and then rotating the turntable. Both polarization of antenna, horizontal and vertical, are measured. The effect of varying the position of the interface cables has been investigated to find the configuration that produces maximum emission.

The highest emissions were also analyzed in details by operating the spectrum analyzer in fixed tuned quasi-peak mode to determine the precise amplitude of the emissions.

In addition, the following test standards are applicable for related tests on the same EUT configuration and operational condition during radiated emission test and conducted emission test:

EN 61000-3-2, EN 61000-3-3, EN 61000-4-2, EN 61000-4-3, EN 61000-4-4, EN 61000-4-5, EN 61000-4-6, EN 61000-4-8 and EN 61000-4-11.

## **4. Modification(s):**

N/A

## **5. Test Software Used**

(A) WinEMC TEST program that continuously generates a complete line of repeating "H" letter was the software used during test.

## 6. Support Equipment Used

### 1. Personal Computer

**CPU** : Intel P4 LGA 775 3.0 GHz  
**FCC ID** : Declaration of Conformity(DoC)  
**Manufacturer** : MSI  
**Model Number** : MS-6728  
**Power Supply** : Switching  
**Power Cord** : N/A  
**Data Cable** : N/A

### 2. Keyboard (KBS1 PS/2)

**FCC ID** : E5XKB5121WTH0110  
**Manufacturer** : BTC  
**Model Number** : 5121W  
**Power Supply** : +5Vdc from PS2 of PC  
**Power Cord** : N/A  
**Data Cable** : 1 > Shielded , Non-detachable,1.6m  
2 > Back Shell : Metal

### 3. Monitor (MON1 15")

**FCC ID** : Declaration of Conformity(DoC)  
**Manufacturer** : SAMSUNG  
**Model Number** : 550S  
**Power Supply** : Switching  
**Power Cord** : Non-Shielded, Detachable, 1.8m  
**Data Cable** : 1 > Shielded , Non-detachable,1.5m  
2 > Back Shell : Metal

### 4. Printer (PRN1)

**FCC ID** : Declaration of Conformity(DoC)  
**Manufacturer** : Hewlett-Packard  
**Model Number** : C2642E  
**Power Supply** : Linear, 30Vdc O/P  
**Power Cable** : Non-Shielded , Detachable,1.7m  
**Data Cable** : 1 > Shielded , Detachable,1m  
2 > Back Shell : Metal

## PEP Testing Laboratory

12-3Fl, No. 27-1, Lane 169, Kang-Ning St., Hsi-Chih,

Taipei Hsien, Taiwan, R. O. C.

TEL: 886-2-26922097 FAX: 886-2-26956236

REPORT NO. : E940698

### **5.Modem (MOD1) × 2**

**FCC ID** : IFAXDM1414

**Manufacturer** : ACEEX

**Model Number** : 1414

**Power Supply** : Linear, 9Vac O/P

**Power Cable** : Non-Shielded , Detachable,1.7m

**Data Cable** : 1 > Shielded , Detachable,1m

2 > Back Shell : Metal

### **6.Mouse (MOUS/1 PS/2)**

**FCC ID** : DZL211106

**Manufacturer** : ACER

**Model Number** : M-S42

**Power Supply** : +5Vdc from PS2 of PC

**Power Cord** : N/A

**Data Cable** : 1 > Shielded , Non-detachable,1.8m

2 > Back Shell : Metal

## 7. EN 55022 Conducted Disturbance Test

Test Standard	Model No.	Result
EN 55022	UC232R	Compliant

### 7.1 Conducted Disturbance Test Limits at Main Ports

Frequency Rang	Limits dB(uV)			
	Class A ITE		Class B ITE	
MHz	Quasi-peak	Average	Quasi-peak	Average
0.15 - 0.50	79	66	66-56	56-46
0.50 - 5.0	73	60	56	46
5.0 - 30	73	60	60	50

Remarks: - If the average limit is met when a quasi-peak detector is used, the EUT shall be deemed to meet both limits and measurement with the average detector is unnecessary.

- The lower limit shall apply at the transition frequency

- The limit decreases linearly with the logarithm of the frequency in the range 0.15MHz to 0.50 MHz.

## PEP Testing Laboratory

12-3Fl, No. 27-1, Lane 169, Kang-Ning St., Hsi-Chih,

Taipei Hsien, Taiwan, R. O. C.

TEL: 886-2-26922097 FAX: 886-2-26956236

REPORT NO. : E940698

### 7.2 Conducted Disturbance Test Setup Photos

< FRONT VIEW >



< REAR VIEW >



## PEP Testing Laboratory

12-3Fl, No. 27-1, Lane 169, Kang-Ning St., Hsi-Chih,

Taipei Hsien, Taiwan, R. O. C.

TEL: 886-2-26922097 FAX: 886-2-26956236

REPORT NO. : E940698

### 7.3 Conducted Disturbance Test Data at Main Ports (LISN)

**Model No.** : UC232R  
**Frequency range** : 150KHz to 30MHz  
**Detector** : Peak Value  
**Temperature** : 28 °C  
**Humidity** : 58 %

**Test Data :** # 1060 < LINE >  
# 1065 < NEUTRAL >

- Note
1. Level = Read Level + Probe (LISN) Factor + Cable Loss
  2. Over Limit = Level – Limit Line = Margin



Data#: 1060 File#: EN55022-B(QP).emi

Date: 2005-09-12 Time: 16:53:20

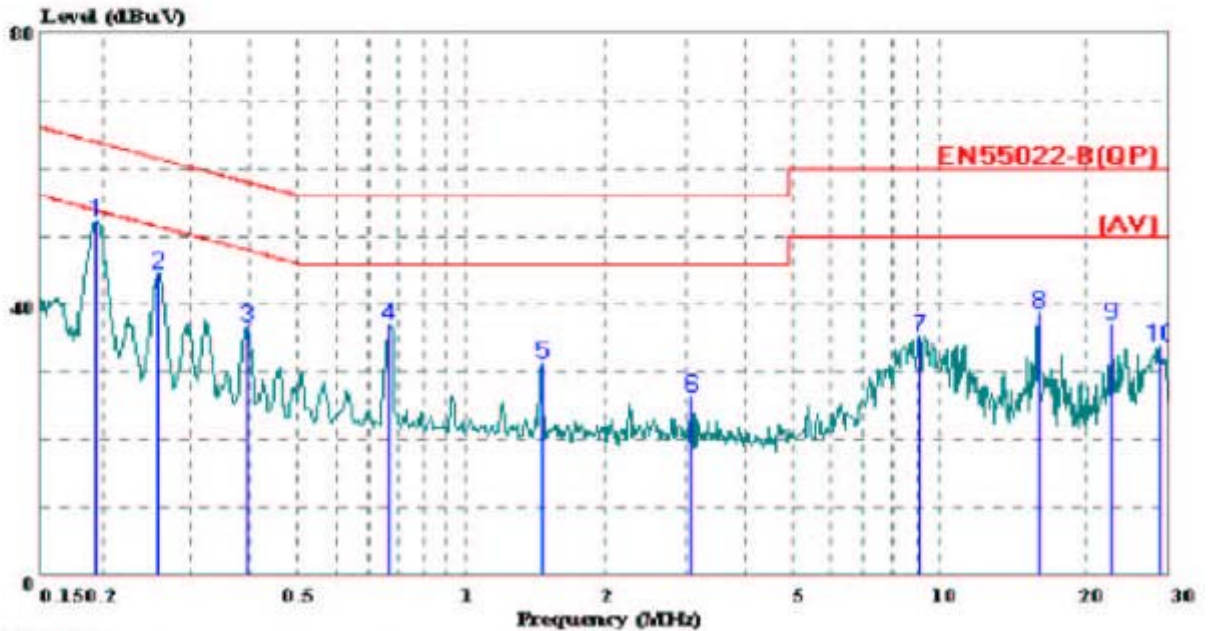

Trace: 1059  
 Site : Conduction No.2(Mick)-Linko site  
 Condition: EN55022-B(QP) LISN.L(32A) LINE  
 Rut : E940698  
 Power : AC 230V 50Hz  
 Memo : Peak Value

Page: 1

	Freq	Level	Over	Limit	Read	Probe	Cable	
	MHz	dBuV	Limit	Line	Level	Factor	Loss	Remark
			dB	dBuV	dBuV	dB	dB	
1	0.193	52.30	-11.59	63.89	52.04	0.20	0.06	
2	0.260	44.43	-16.99	61.42	44.11	0.20	0.12	
3	0.393	36.59	-21.40	57.99	36.24	0.20	0.15	
4	0.767	36.86	-19.14	56.00	36.45	0.20	0.21	
5	1.568	31.24	-24.76	56.00	30.75	0.20	0.29	
6	3.173	26.48	-29.52	56.00	25.91	0.20	0.37	
7	9.204	35.40	-24.60	60.00	34.58	0.29	0.53	
8	16.140	38.78	-21.22	60.00	37.40	0.67	0.71	
9	22.775	36.90	-23.10	60.00	35.09	1.01	0.80	
10	28.603	33.96	-26.04	60.00	31.84	1.24	0.88	



Data#: 1065 File#: EN55022-B(QP).emi Date: 2005-09-12 Time: 16:54:56

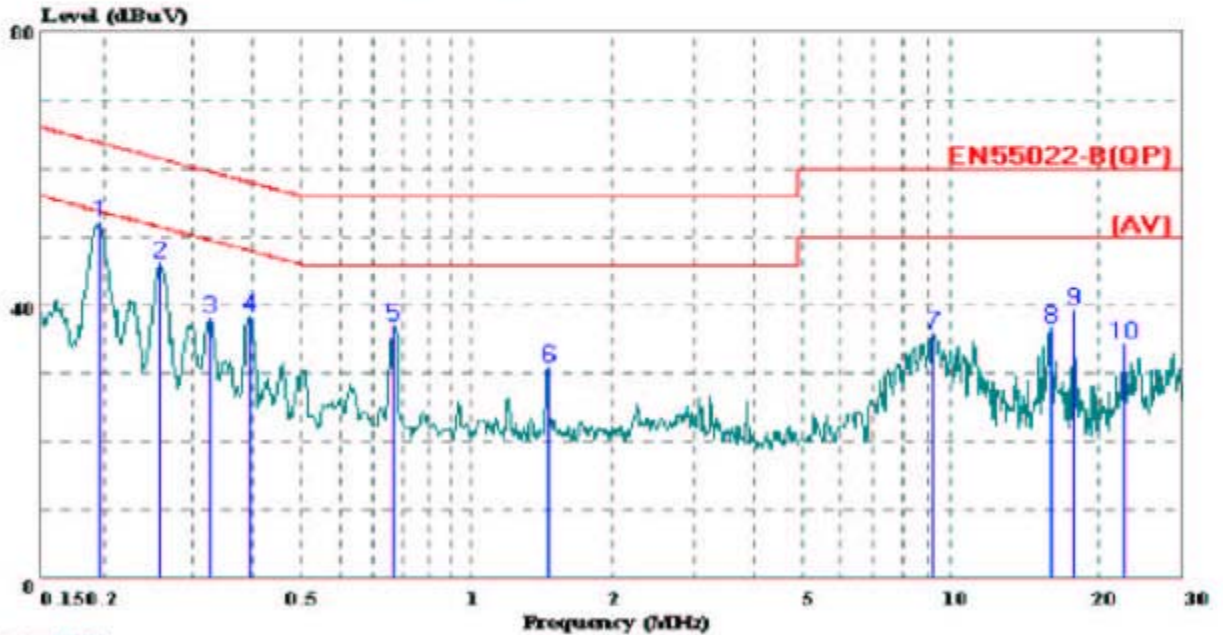

Trace: 1064  
 Site : Conduction No.2(Mick)-Linko site  
 Condition: EN55022-B(QP) LISN.N(32A) NEUTRAL  
 Eut : E940698  
 Power : AC 230V 50Hz  
 Memo : Peak Value

Page: 1

	Freq	Level	Over Limit	Limit Line	Read Level	Probe Factor	Cable Loss	Remark
	MHz	dBuV	dB	dBuV	dBuV	dB	dB	
1	0.195	52.05	-11.75	63.80	51.89	0.10	0.06	
2	0.260	46.15	-15.27	61.42	45.93	0.10	0.12	
3	0.327	38.07	-21.46	59.53	37.82	0.10	0.15	
4	0.396	38.46	-19.49	57.95	38.21	0.10	0.15	
5	0.767	37.11	-18.89	56.00	36.80	0.10	0.21	
6	1.568	31.11	-24.89	56.00	30.65	0.17	0.29	
7	9.401	35.78	-24.22	60.00	35.14	0.11	0.53	
8	16.140	36.62	-23.38	60.00	35.56	0.35	0.71	
9	18.039	39.24	-20.76	60.00	38.07	0.43	0.74	
10	22.655	34.47	-25.53	60.00	33.06	0.61	0.80	

## 8. EN 55022 Radiated Disturbance Test

Test Standard	Model No.	Result
EN 55022	UC232R	Compliant

### 8.1 Radiated Disturbance Test Description

Preliminary measurements were made indoors chamber at 3 meter using broadband antennas, broadband amplifier, and spectrum analyzer to determine the frequency producing the maximum EME. Appropriate precaution was taken to ensure that all EME from the EUT were maximized and investigated. The system configuration, clock speed, mode of operation or video resolution, turntable azimuth with respect to the antenna were noted for each frequency found. The spectrum was scanned from 30 to 1000 MHz using logbicon antenna. Above 1GHz, linearly polarized double ridge horn antenna were used.

Final measurements were made outdoors at 10-meter test range using biconical, dipole antenna or horn antenna. The test equipment was placed on a wooden bench situated on a 1.5x1 meter area adjacent to the measurement area. Sufficient time for the EUT, support equipment, and test equipment was allowed in order for them to warm up to their normal operating condition. Each frequency found during pre-scan measurements was re-examined and investigated using Quasi-Peak Adapter. The detector function was set to CISPR quasi-peak mode and the bandwidth of the receiver was set to 120kHz.

The half-wave dipole antenna was tuned to the frequency found during preliminary radiated measurements. The EUT, support equipment and interconnecting cables were re-configured to the set-up producing the maximum emission for the frequency and were placed on top of a 0.8-meter high non-metallic 1 x 1.5 meter table. The EUT, support equipment, and interconnecting cables were re-arranged and manipulated to maximize each EME emission. The turntable containing the system was rotated; the antenna height was varied 1 to 4 meters and stopped at the azimuth or height producing the maximum emission.

## 8.2 Radiated Disturbance Test Setup

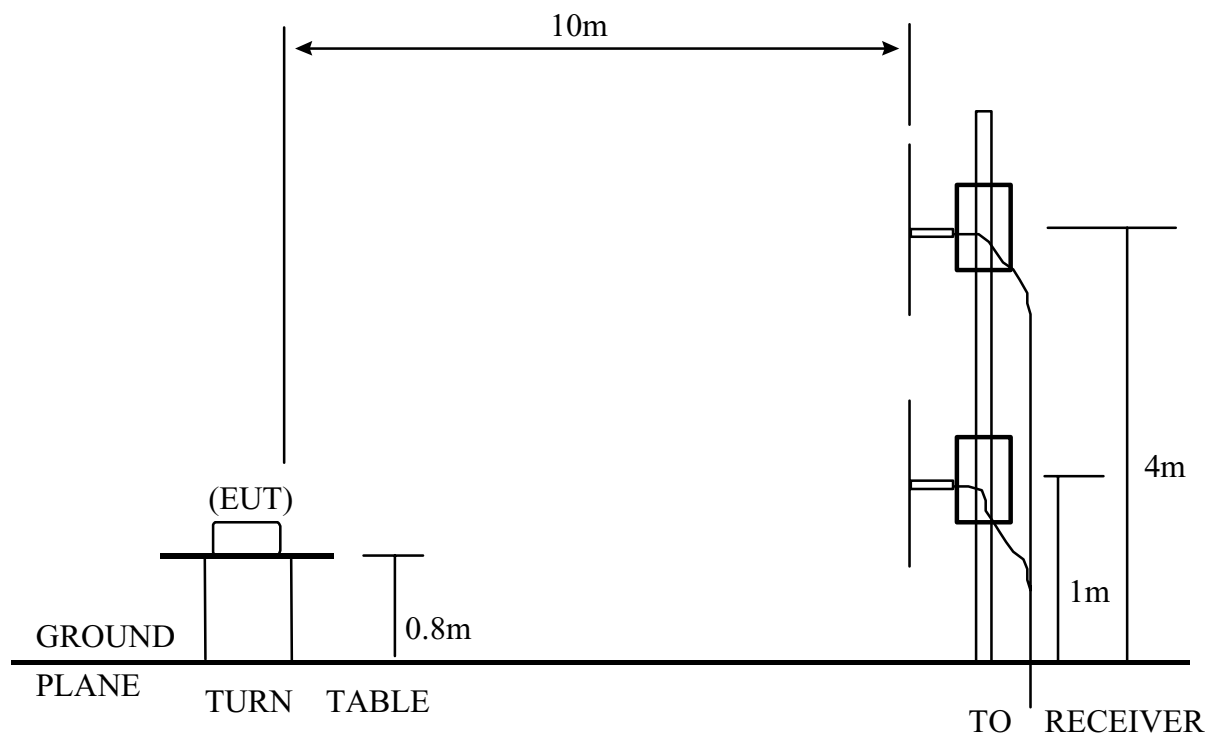

EUT = Equipment Under Test

### 8.3 Radiated Disturbance Test Limits

Limits for radiated disturbance of Class A ITE at  
a measuring distance of 10 m

Frequency MHz	Field Strength dB( $\mu$ V/m)
30 to 230	40
230 to 1 000	47

NOTES

- 1 The lower limit shall apply at the transition frequency.
- 2 Additional provisions may be required for cases where interference occurs.

Limits for radiated disturbance of Class B ITE at  
a measuring distance of 10 m

Frequency MHz	Field Strength dB( $\mu$ V/m)
30 to 230	30
230 to 1 000	37

NOTES

- 1 The lower limit shall apply at the transition frequency.
- 2 Additional provisions may be required for cases where interference occurs.

## 8.4 Radiated Disturbance Test Setup Photos

< FRONT VIEW >



< REAR VIEW >



# PEP Testing Laboratory

12-3FI, No. 27-1, Lane 169, Kang-Ning St., Hsi-Chih,  
Taipei Hsien, Taiwan, R. O. C.

TEL: 886-2-26922097 FAX: 886-2-26956236

REPORT NO. : E940698

## 8.5 Radiated Disturbance Test Data

**Model No.** : UC232R  
**Frequency range** : 30MHz to 1GHz **Detector** : Quasi-Peak Value  
**Temperature** : 33 ° C **Humidity** : 61 %

**Antenna polarization** : HORIZONTAL ; **Test distance** : 10m ;

Freq. (MHz)	Level (dBuV/m)	Over Limit (dB)	Limit Line (dBuV/m)	Read Level (dBuV)	Antenna Factor (dB)	Cable Loss (dB)	Preamp Factor (dB)	Azimuth (°angle)	Antenna High(m)
110.780	21.99	-8.01	30.00	29.62	11.86	0.81	20.30	283.0	4.0
131.007	20.42	-9.58	30.00	26.70	13.08	0.94	20.30	195.0	4.0
150.131	22.24	-7.76	30.00	26.04	15.40	1.10	20.30	244.0	4.0
170.311	22.45	-7.55	30.00	27.73	13.85	1.17	20.30	304.0	3.9
209.036	20.06	-9.94	30.00	28.05	10.81	1.40	20.20	274.0	3.7
327.780	19.93	-17.07	37.00	25.03	13.30	1.79	20.19	185.0	3.4

Note :

1. Level = Read Level + Antenna Factor + Cable Loss – Preamp Factor
2. Over Limit = Level – Limit Line

# PEP Testing Laboratory

12-3FI, No. 27-1, Lane 169, Kang-Ning St., Hsi-Chih,  
Taipei Hsien, Taiwan, R. O. C.

TEL: 886-2-26922097 FAX: 886-2-26956236

REPORT NO. : E940698

**Model No. : UC232R**  
**Frequency range : 30MHz to 1GHz**    **Detector : Quasi-Peak Value**  
**Temperature : 33 ° C**                    **Humidity : 61 %**

**Antenna polarization : VERTICAL ; Test distance : 10m ;**

Freq. (MHz)	Level (dBuV/m)	Over Limit (dB)	Limit Line (dBuV/m)	Read Level (dBuV)	Antenna Factor (dB)	Cable Loss (dB)	Preamp Factor (dB)	Azimuth (°angle)	Antenna High(m)
110.744	19.51	-10.49	30.00	27.14	11.86	0.81	20.30	101.0	1.0
129.953	21.16	-8.84	30.00	27.57	12.96	0.93	20.30	272.0	1.0
149.693	20.28	-9.72	30.00	24.14	15.34	1.10	20.30	312.0	1.0
170.329	17.53	-12.47	30.00	22.81	13.85	1.17	20.30	287.0	1.2
209.016	19.85	-10.15	30.00	27.84	10.81	1.40	20.20	195.0	1.4
327.358	21.96	-15.04	37.00	27.06	13.30	1.79	20.19	147.0	1.8

Note :

1. Level = Read Level + Antenna Factor + Cable Loss – Preamp Factor
2. Over Limit = Level – Limit Line

## 9. EN 61000-3-2 Harmonic Current Test

Test standard	Model No.	Result
EN 61000-3-2	UC232R	Compliant

### 9.1 Harmonic Current Test Description

The equipment under test is supplied in series with shunt(s) Rm or current transformer(s) from a source having the same nominal voltage and frequency as the rated supply voltage and frequency of the equipment under test. Whether the equipment operates with automatic, mixed or manual control, the measurements shall be made under normal load, or conditions for adequate heat discharge, and under normal operating conditions.

User's operation controls or automatic programmers shall be set to produce the maximum harmonic component, for each successive harmonic component in turn.

For the purpose of harmonic current limitation, equipment is classified as follows:

Class A:

- Balanced three-phase equipment;
- Household appliances excluding equipment identified as Class D;
- Tools excluding portable tools;
- Dimmers for incandescent lamps;
- Audio equipment.

Equipment not specified in one of the three other classes shall be considered as Class A equipment.

NOTE 1 Equipment that can be shown to have a significant effect on the supply system may be reclassified in a future edition of the standard. Factors to be taken into account include:

- number in use;
- duration of use;
- simultaneity of use;
- power consumption;
- harmonic spectrum, including phase.

Class B: Portable tools.

- Portable tools;
- Arc welding equipment which is not professional equipment.

Class C:

- Lighting equipment.

Class D:

Equipment having a specified power according to 6.2.2 less than or equal to 600W, of the following types:

- Personal computers and personal computer monitors;
- Television receivers.

NOTE 2 Class D limits are reserved for equipment that, by virtue of the factors listed in note 1, can be shown to have a pronounced effect on the public electricity supply system.

### 9.2 Flow-chart for determining Conformity

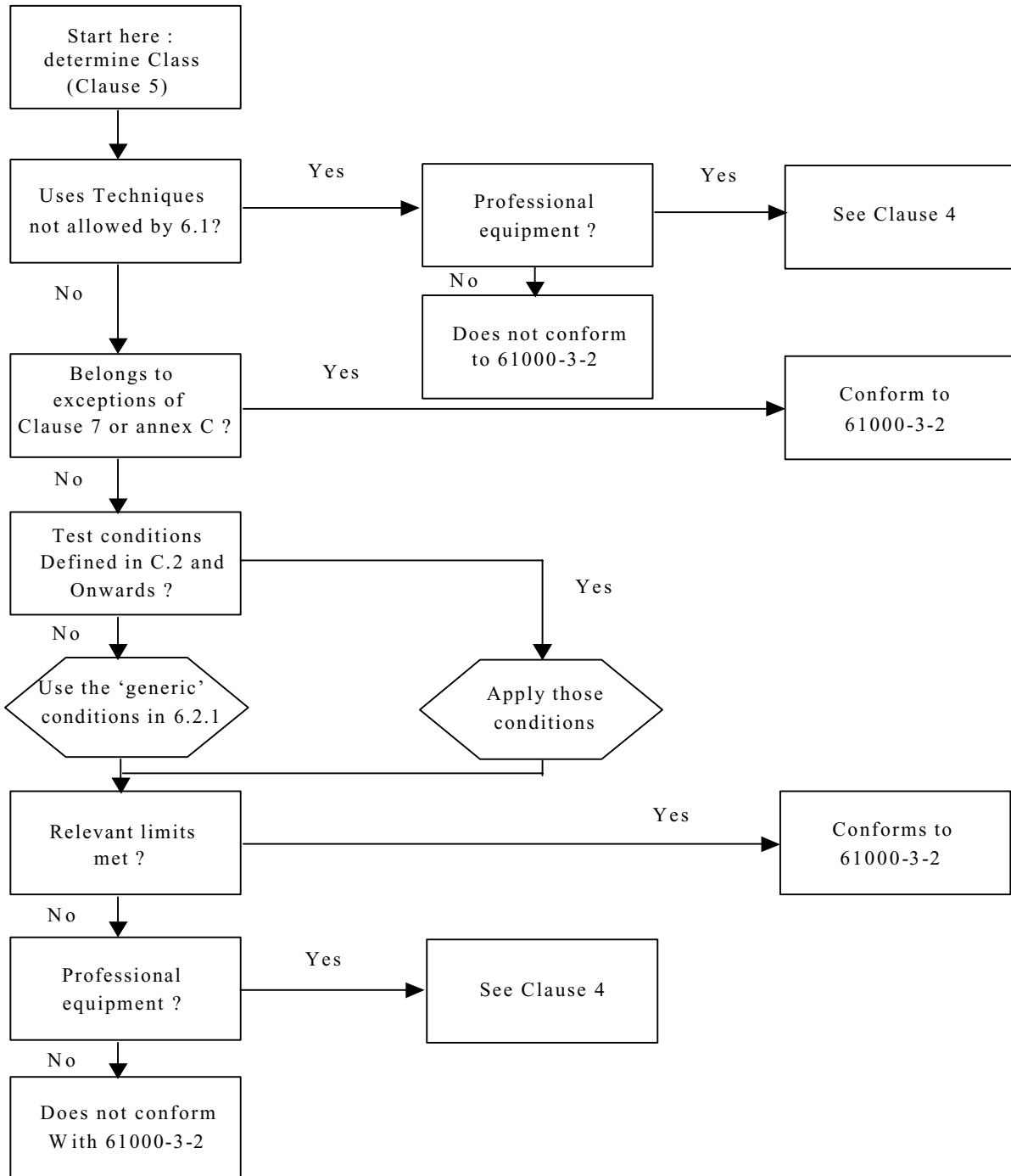

### 9.3 Harmonic Current Test Setup

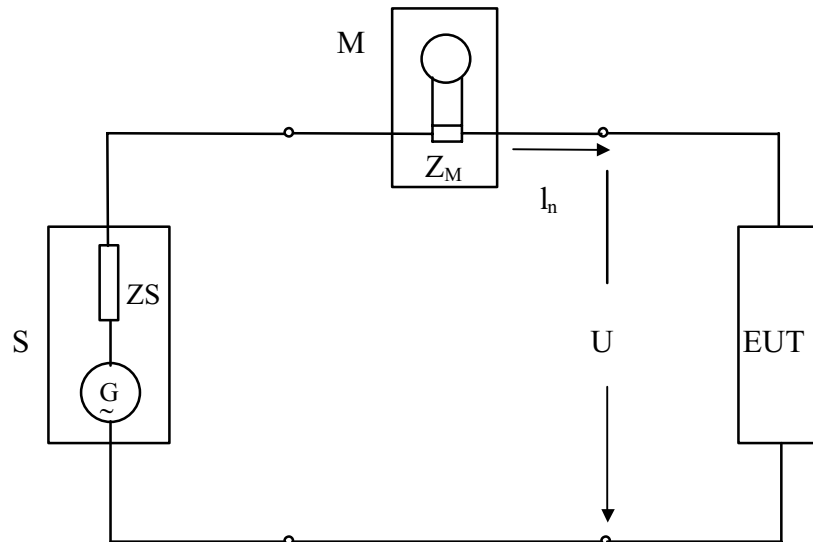

S power supply source

M measurement equipment

EUT equipment under test

U test voltage

Z<sub>M</sub> input impedance of measurement equipment

Z<sub>S</sub> internal impedance of the supply source

I<sub>n</sub> harmonic component of order n of the line current

G open-loop voltage of the supply source

## 9.4 Harmonic Current Test Limits

Table 1 Limits for Class A equipment

Harmonic order n	Maximum permissible harmonic current A
Odd harmonics	
3	2.30
5	1.14
7	0.77
9	0.40
11	0.33
13	0.21
15 ≤ n ≤ 39	0.15 $\frac{15}{n}$
Even harmonics	
2	1.08
4	0.43
6	0.30 $\frac{8}{n}$
8 ≤ n ≤ 40	0.23 $\frac{8}{n}$

Note :

1. For Class A equipment, the harmonics of the input current shall not exceed the absolute values given in table 1.
2. For Class B equipment, the harmonics of the input current shall not exceed the values given in table 1 multiplied by a factor of 1,5.

Table 2 Limits for Class C equipment

Harmonic order n	Maximum permissible harmonic current expressed as a percentage of the input current at the fundamental frequency %
2	2
3	$30 \cdot \lambda^*$
5	10
7	7
9	5
$11 \leq n \leq 39$ (odd harmonics only)	3

\*  $\lambda$  is the circuit power factor

Note :

The harmonic current limits of lighting equipment shall not exceed the relative limits given in table 2.

Table 3 Limits for Class D equipment

Harmonic n	Maximum permissible harmonic current per watt mA/W	Maximum permissible harmonic current A
3	3.4	2.30
5	1.9	1.14
7	1.0	0.77
9	0.5	0.40
11	0.35	0.33
$13 \leq n \leq 39$ (odd harmonics only)	$\frac{3.85}{n}$	See table 1

Note :

The harmonics of the input current shall not exceed the values that can be derived from table 3.

## PEP Testing Laboratory

12-3FI, No. 27-1, Lane 169, Kang-Ning St., Hsi-Chih,  
Taipei Hsien, Taiwan, R. O. C.

TEL: 886-2-26922097 FAX: 886-2-26956236

REPORT NO. : E940698

### 9.5 Harmonic Current Test Setup Photo

< FRONT VIEW >



## 9.6 Harmonic Current Test Data

Model : UC232R  
 Line Voltage : 230 Vrms  
 RMS Current : 0.296 A  
 Real Power : 59.54 W  
 Fundamental Amp : 892.8 mArms  
 Line Frequency : 50 Hz  
 Device Class : A

Harm. Order	Indicated Values	Max. Permits Harm. Current Ampere
---	---	---
3	0.086	2.30
5	0.018	1.14
7	0.008	0.77
9	0.006	0.40
11	0.010	0.33
13	0.008	0.21
15	0.005	0.15
17	0.010	0.13
19	0.006	0.12
21	0.005	0.11
23	0.004	0.10
25	0.002	0.09
27	0.006	0.08
29	0.004	0.08
31	0.002	0.07
33	0.003	0.07
35	0.002	0.06
37	0.002	0.06
39	0.002	0.06

Harm. Order	Indicated Values	Max. Permits Harm. Current Ampere
2	0.004	1.08
4	0.000	0.43
6	0.000	0.30
8	0.000	0.23
10	0.000	0.18
12	0.001	0.15
14	0.001	0.13
16	0.001	0.12
18	0.001	0.10
20	0.001	0.09
22	0.000	0.08
24	0.000	0.08
26	0.000	0.07
28	0.000	0.07
30	0.000	0.06
32	0.000	0.06
34	0.000	0.05
36	0.000	0.05
38	0.000	0.05
40	0.000	0.05

## **10. EN 61000-3-3 Voltage Fluctuations Test**

Test Standard	Model No.	Result
EN 61000-3-3	UC232R	Compliant

### **10.1 Voltage Fluctuations Test Description**

EN 61000-3-3 standards define the measurement requirements, ac power source requirements, line impedance requirements, and voltage fluctuation and flicker limits for assessing electronic and electrical equipment's propensity to cause voltage disturbances on the ac mains. Compliance with these standards ensures that voltage fluctuations do not interfere with other equipment connected to the ac mains or cause incandescent lights to visibly flicker in a way that causes an annoyance or health risk to a human observer.

When automatic controls cycle on and off, they cause frequent changes of toehold to the supply. When the fluctuating load is in a branch circuit with other loads, these changes cause rms voltage fluctuations that affect all of the loads in the branch. In particular, variations in voltage amplitude cause changes in the light output of any filament lamps in the branch circuit. Because the output of a filament lamp is proportional to the square of the applied voltage, changes in light intensities can be significant even for small changes in voltage.

## 10.2 Voltage Fluctuations Test Limits

The limits shall be applicable to voltage fluctuations and flicker at the supply terminals of the equipment under test.

The following limits apply:

- the value of  $P_{st}$  shall not be greater than 1.0;
- the value of  $P_{it}$  shall not be greater than 0.65;
- the value of  $d(t)$  during a voltage change shall not exceed 3.3% for more than 500 ms;
- the relative steady-state voltage change,  $d_c$ , shall not exceed 3.3%;
- the maximum relative voltage change  $d_{max}$ , shall not exceed
  - a) 4% without additional conditions;
  - b) 6% for equipment which is:
    - switched manually, or
    - switched automatically more frequently than twice per day, and also has either a delayed restart (the delay being not less than a few tens of seconds), or manual restart, after a power supply interruption.

NOTE The cycling frequency will be frequency will be further limited by the  $P_{st}$  and  $P_{it}$  limit. For example: a  $d_{max}$  of 6% producing a rectangular voltage change characteristic twice per hour will give a  $P_{it}$  of about 0.65.

- c) 7% for equipment which is
  - attended whilst in use (for example: hair dryers, vacuum cleaners, kitchen equipment such as mixers, garden equipment such as lawn mowers, portable tools such as electric drills), or
  - switched on automatically, or is intended to be switched on manually, no mote than twice per day, and also has either a delayed restart (the delay being not less than a few tens of seconds) or manual restart, after a power supply interruption.

## 10.3 Voltage Fluctuations Test Setup Photo

< FRONT VIEW >



## 10.4 Voltage Fluctuations Test Data

Model No : \_\_\_\_\_ UC232R \_\_\_\_\_

RMS Voltage	: 230 V	RMS Current	: 0.285 A
Real Power	: 56.79 W	Peak Current	: 0.501 A
Apparent Power	: 65.39 VA	Frequency	: 50.0 Hz

	Indicated Values	Limit	Pass(P) or Fail (F)
Pst	0.072	< 1.0	P
Plt	0.072	< 0.65	P
Dc	0.00%	< 3.3%	P
Dmax	0.00%	< 4%	P
D(t)	0.00%	< 3.3%	P

Pst : Short-term flicker indicator

Plt : Long-term flicker indicator

Dc : Relative steady state voltage change

Dmax : Maximum relative voltage change

D (t) : Voltage change

## PEP Testing Laboratory

12-3FI, No. 27-1, Lane 169, Kang-Ning St., Hsi-Chih,  
Taipei Hsien, Taiwan, R. O. C.

TEL: 886-2-26922097 FAX: 886-2-26956236

REPORT NO. : E940698

### 11. EN 61000-4-2 Electrostatic Discharge Test

Test Standard	Model No.	Result
EN 61000-4-2	UC232R	B

**The test results shall be classified on the basis of the operating conditions and the functional specifications of the equipment under test , as in the following , unless different specifications are given by product committees or product specifications :**

***Performance Criterion :***

***A) normal performance within the specification limits ;***

***B) temporary degradation or loss of function or performance which is self-recoverable ;***

***C) temporary degradation or loss of function or performance which requires operator intervention or system reset ;***

## **11.1 Electrostatic Discharge Test Description**

This standard relates to equipment, systems, sub-systems and peripherals which may be involved in static electricity discharges owing to environmental and installation conditions. such as low relative humidity, use of low-conductivity (artificial-fiber) carpets, vinyl garments, etc., which may exist in allocations classified in standards relevant to electrical and electronic equipment.

The test set-up shall consist of a wooden table, 0.8 m high standing on the ground reference plane. A horizontal coupling plane(HCP), 1.6 m x 0.8 m, shall be placed on the table. The EUT and cables shall be isolated from the coupling plane by an insulating support 0.5 mm thick .

A ground reference plane shall be provided on floor of the laboratory. It shall be metallic sheet of 0.25 mm minimum thickness. The minimum size of the reference plane is 1 m, the exact size depending on the dimensions of the EUT .

It shall project beyond the EUT or coupling plane by at least 0.5 m on all sides. and shall be connected to the protective grounding system.

In order to minimize the impact of environmental parameters on test results, the tests shall be carried out in climatic and electromagnetic reference conditions.

### **Climatic conditions**

- ambient temperature: 15 °C to 35°C;
- relative humidity: 30 % to 60%
- atmospheric pressure: 86 KPa (860 mbar) to 106 KPa (1060 mbar).

NOTE – Any other values are specified in the product specification.

### **Electromagnetic conditions**

The electromagnetic environment of the laboratory shall not influence the test results.

## 11.2 Electrostatic Discharge Test Setup

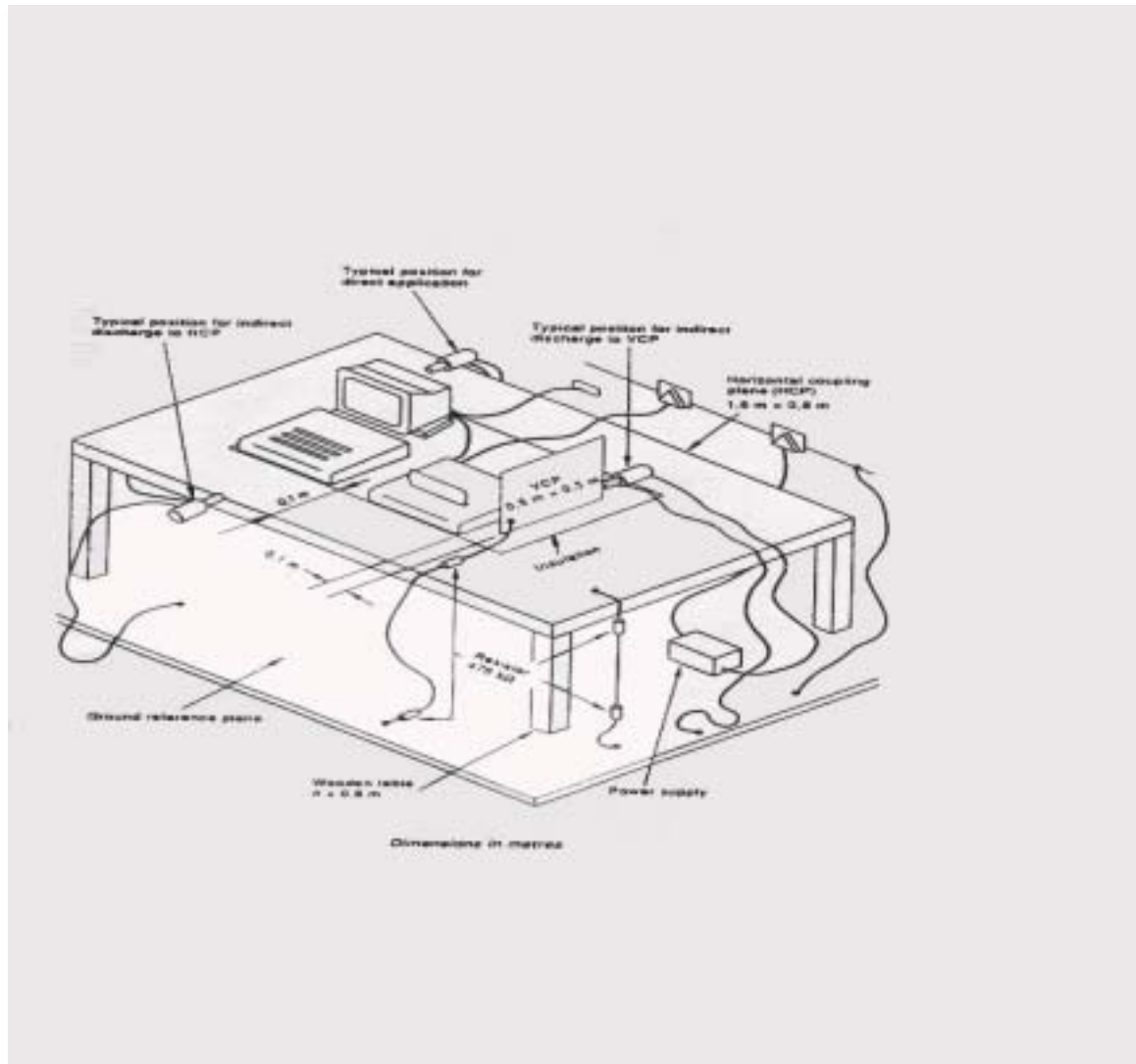

- Example of test set-up for table-top equipment,  
laboratory tests

### 11.3 Electrostatic Discharge Test Limits

Test levels

Contact discharge		Air discharge	
Level	Test voltage kv	Level	Test voltage
1	2	1	2
2	4	2	4
3	6	3	8
4	8	4	15
x <sup>1)</sup>	Special	x <sup>1)</sup>	Special

<sup>1)</sup> "x" is an open level . The level has to be specified in the dedicated equipment specification .

If higher voltages than those shown are specified , special test equipment may be needed .

### 11.4 Direct Discharge Test Drawing

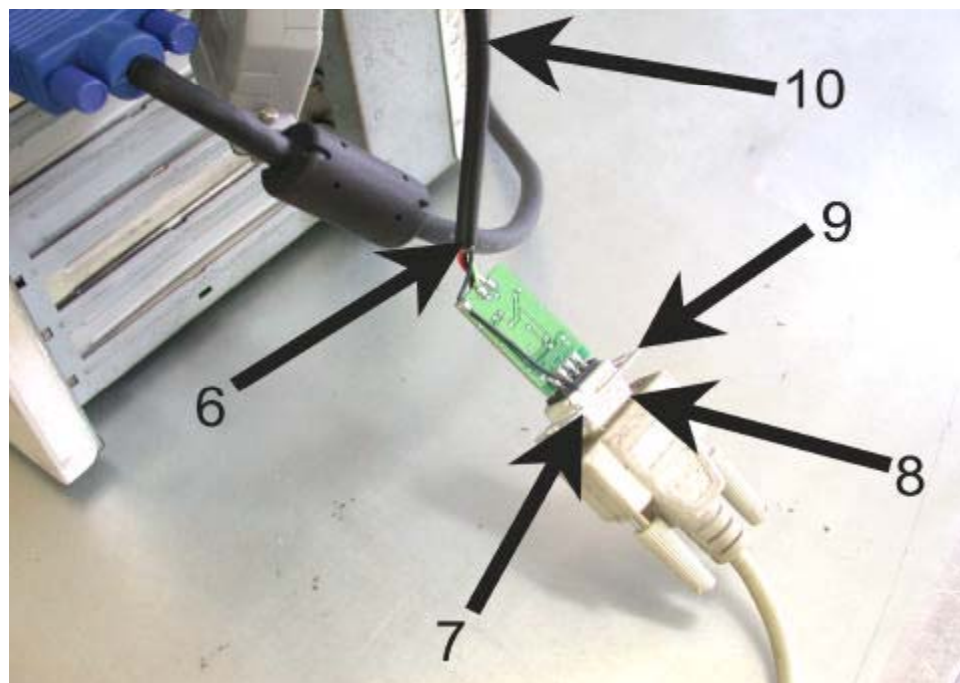
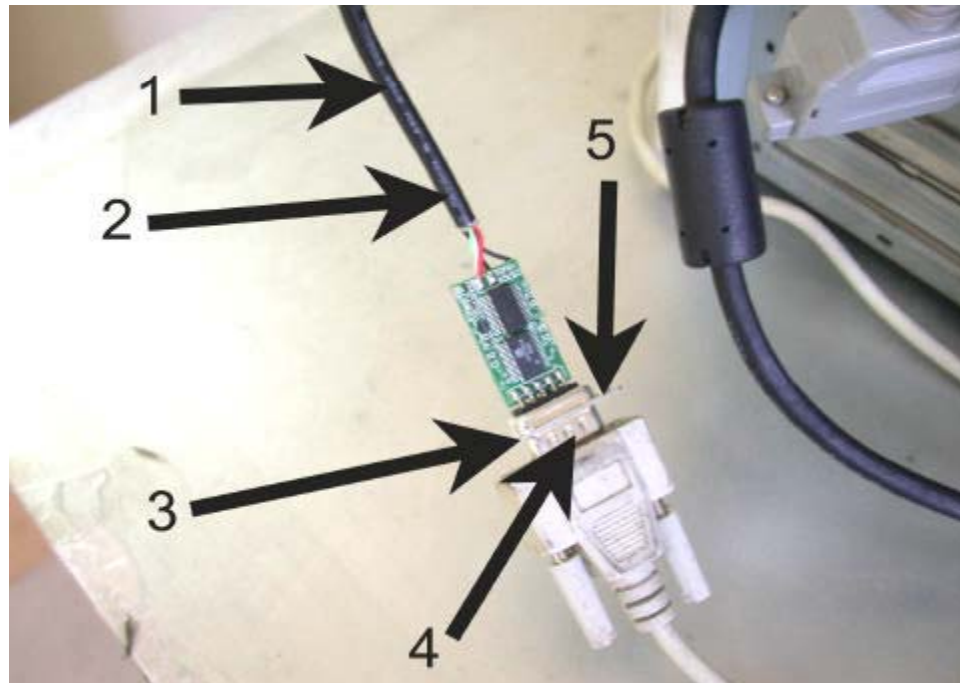

## Indirect Discharge Test Drawing

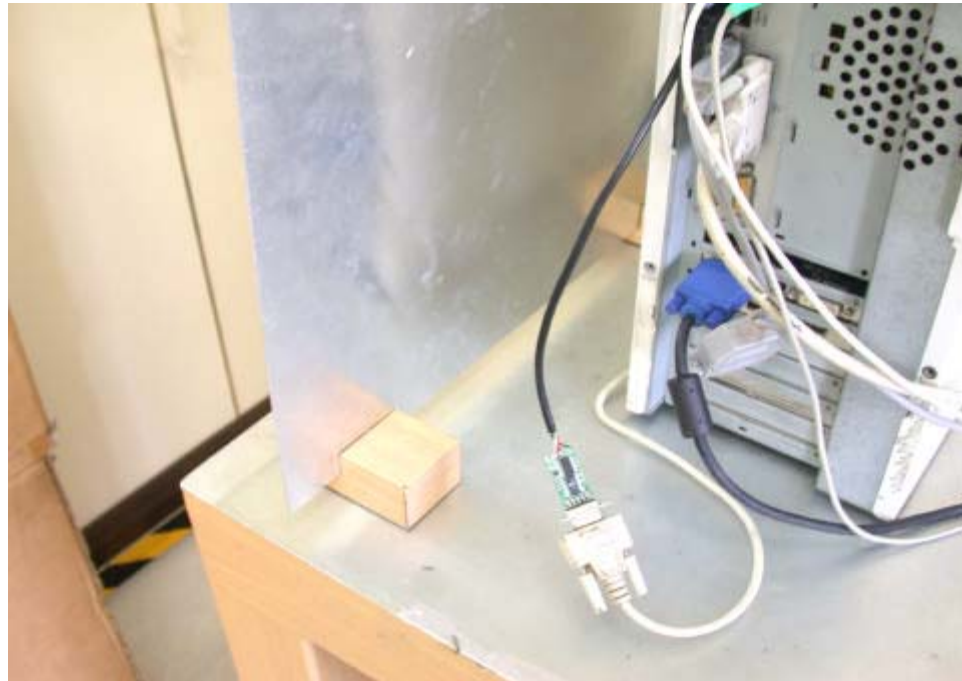

**PEP Testing Laboratory**

12-3FI, No. 27-1, Lane 169, Kang-Ning St., Hsi-Chih,  
 Taipei Hsien, Taiwan, R. O. C.  
 TEL: 886-2-26922097 FAX: 886-2-26956236

REPORT NO. : E940698

### 11.5 Electrostatic Discharge Test Data (Direct Discharge)

Model No. : UC232R

Test Item : <b>Direct Discharge</b>		Instrument : NoiseKen ESS-100L															
Temperature : <u>28</u> °C		Relative Humidity : <u>52</u> %RH															
Storage Capacitor : 150 pf		Discharge Resistor : 330 Ohm															
Discharge Rate : < 1 / Sec																	
	Contact Discharge								Air Discharge								
	2 KV		4 KV		6 KV		8 KV		2 KV		4 KV		6 KV		8 KV		
	+	-	+	-	+	-	+	-	+	-	+	-	+	-	+	-	
1	P	P	P	P	/	/	/	/	P	P	P	P	P	P	P	P	P
2	/	/	/	/	/	/	/	/	P	P	P	P	P	P	P	P	P
3	/	/	/	/	/	/	/	/	P	P	P	P	P	P	P	P	P
4	/	/	/	/	/	/	/	/	P	P	P	P	P	P	P	P	P
5	/	/	/	/	/	/	/	/	P	P	P	P	P	P	P	P	P
6	/	/	/	/	/	/	/	/	P	P	P	P	P	P	P	P	P
7	/	/	/	/	/	/	/	/	P	P	P	P	P	P	P	P	P
8	/	/	/	/	/	/	/	/	P	P	P	P	P	P	P	P	P
9	/	/	/	/	/	/	/	/	P	P	P	P	P	P	P	P	P
10	/	/	/	/	/	/	/	/	P	P	P	P	P	P	P	P	P

1. " P " - - - - means the EUT function is correct during the test.
2. " / " - - - - no test.

**PEP Testing Laboratory**

12-3FI, No. 27-1, Lane 169, Kang-Ning St., Hsi-Chih,  
 Taipei Hsien, Taiwan, R. O. C.  
 TEL: 886-2-26922097 FAX: 886-2-26956236

REPORT NO. : E940698

**Electrostatic Discharge Test Data (Indirect Discharge)**

Model No. : \_\_\_\_\_ UC232R \_\_\_\_\_

Test Item : <b>Indirect Discharge</b>		Instrument : NoiseKen ESS-100L															
Temperature : <u>28</u> °C		Relative Humidity : <u>52</u> %RH															
Storage Capacitor : 150 pf		Discharge Resistor : 330 Ohm															
Discharge Rate : < 1 / Sec																	
	Contact Discharge								Air Discharge								
	2 KV		4 KV		6 KV		8 KV		2 KV		4 KV		6 KV		8 KV		
	+	-	+	-	+	-	+	-	+	-	+	-	+	-	+	-	
1	P	P	P	P	/	/	/	/	/	/	/	/	/	/	/	/	/
2	P	P	P	P	/	/	/	/	/	/	/	/	/	/	/	/	/
3	P	P	P	P	/	/	/	/	/	/	/	/	/	/	/	/	/
4	/	/	/	/	/	/	/	/	/	/	/	/	/	/	/	/	/
5	/	/	/	/	/	/	/	/	/	/	/	/	/	/	/	/	/
6	/	/	/	/	/	/	/	/	/	/	/	/	/	/	/	/	/
7	/	/	/	/	/	/	/	/	/	/	/	/	/	/	/	/	/
8	/	/	/	/	/	/	/	/	/	/	/	/	/	/	/	/	/
9	/	/	/	/	/	/	/	/	/	/	/	/	/	/	/	/	/
10	/	/	/	/	/	/	/	/	/	/	/	/	/	/	/	/	/

1. " P " - - - - means the EUT function is correct during the test.
2. " / " - - - - no test.

## 12. EN 61000-4-3 Radio-Frequency Electromagnetic Field Test

Test Standard	Model No.	Result
EN 61000-4-3	UC232R	A

Field Strength : 3 V/M , Level 2 .

Modulation : AM 80 % , 1KHz . ON (YES) . OFF (\_\_\_)

Start : 80 MHz , Stop : 1000 MHz . AC Power : 230 Vac

DC Power : N/A Vdc

**The test results shall be classified on the basis of the operating conditions and the functional specifications of the equipment under test , as in the following , unless different specifications are given by product committees or product specifications :**

***Performance Criterion :***

***A) normal performance within the specification limits ;***

***B) temporary degradation or loss of function or performance which is self-recoverable ;***

***C) temporary degradation or loss of function or performance which requires operator intervention or system reset ;***

## **12.1 Radio-Frequency Electromagnetic Field Test Description**

Most electronic equipment is, in some manner, affected by electromagnetic radiation.

This radiation is frequently generated by such sources as the small hand-held radio transceivers that are used by operating, maintenance and security personnel, fixed-station radio and television transmitters, vehicle radio transmitters, and various industrial electromagnetic sources.

In addition to electromagnetic energy deliberately generated, there is also spurious radiation caused by devices such as welders, thyristors, fluorescent lights, switches operating inductive loads, etc. For the most part, this interference manifests itself as conducted electrical interference and, as such, is dealt with in other parts of this standard. Methods employed to prevent effects from electromagnetic fields will normally also reduce the effects from these sources.

The electromagnetic environment is determined by the strength of the electromagnetic field (field strength in volts per meter). The field strength is not easily measured without sophisticated instrumentation nor is it easily calculated by classical equations and formulae because of the effect of surrounding structures or the proximity of other equipment that will distort and/or reflect the electromagnetic waves.

All testing of equipment shall be performed in a configuration as close as possible to the installed case. Wiring shall be consistent with the manufacturer's recommended procedures, and the equipment shall be in its housing with all covers and access panels in place, unless otherwise stated.

If the equipment is designed to be mounted in a panel, rack or cabinet, it shall be tested in this configuration.

## 12.2 Radio-Frequency Electromagnetic Field Test Block Diagram

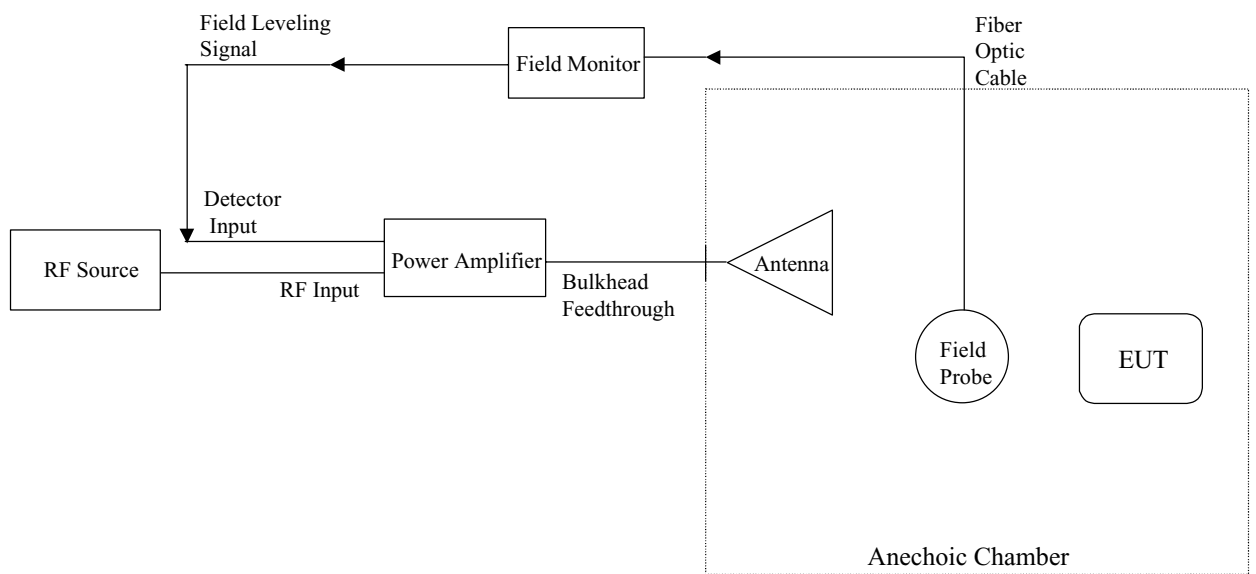

## 12.3 Radio-Frequency Electromagnetic Field Test Limits

Table 1 - Test levels

Level	Test field strength V/m
1	1
2	3
3	10
x	Special

NOTE – x is an open test level. This level may be given in the Product specification.

Table 1 gives details of the field strength of the unmodulated signal. For testing of equipment, this signal is 80 % amplitude modulate with a 1 KHz sinewave to simulate actual threats.

## 12.4 Radio-Frequency Electromagnetic Field Test Setup Photo

< FRONT VIEW >



### **13. EN 61000-4-4 Fast Transient Burst Test**

Test standard	Model No.	Result
EN 61000-4-4	UC232R	B

**The test results shall be classified on the basis of the operating conditions and the functional specifications of the equipment under test , as in the following , unless different specifications are given by product committees or product specifications :**

***Performance Criterion :***

***A) normal performance within the specification limits ;***

***B) temporary degradation or loss of function or performance which is self-recoverable ;***

***C) temporary degradation or loss of function or performance which requires operator intervention or system reset ;***

## **13.1 Fast Transient Bursts Test Description**

The repetitive fast transient test is a test with bursts consisting of a number of fast transients, coupled into power supply, control and signal ports of electrical and electronic equipment. Significant for the test are the short rise time, the repetition rate and the low energy of the transients.

The test shall be carried out on the basis of a test plan including verification of the performances of the EUT as defined in the technical specification.

### **Climatic conditions**

The tests shall be carried out in standard climatic conditions in accordance with IEC 68-1:

- ambient temperature: 15°C to 35°C
- relative humidity: 25% to 75%
- atmospheric pressure: 86kPa (860 mbar) to 106Kpa (1060 mbar)

NOTE – Any other values are specified in the product specification.

### **Electromagnetic conditions**

The electromagnetic conditions of the laboratory shall be such to guarantee the correct operation of the EUT in order not to influence the test results.

### 13.2 Fast Transient Burst Test Setup

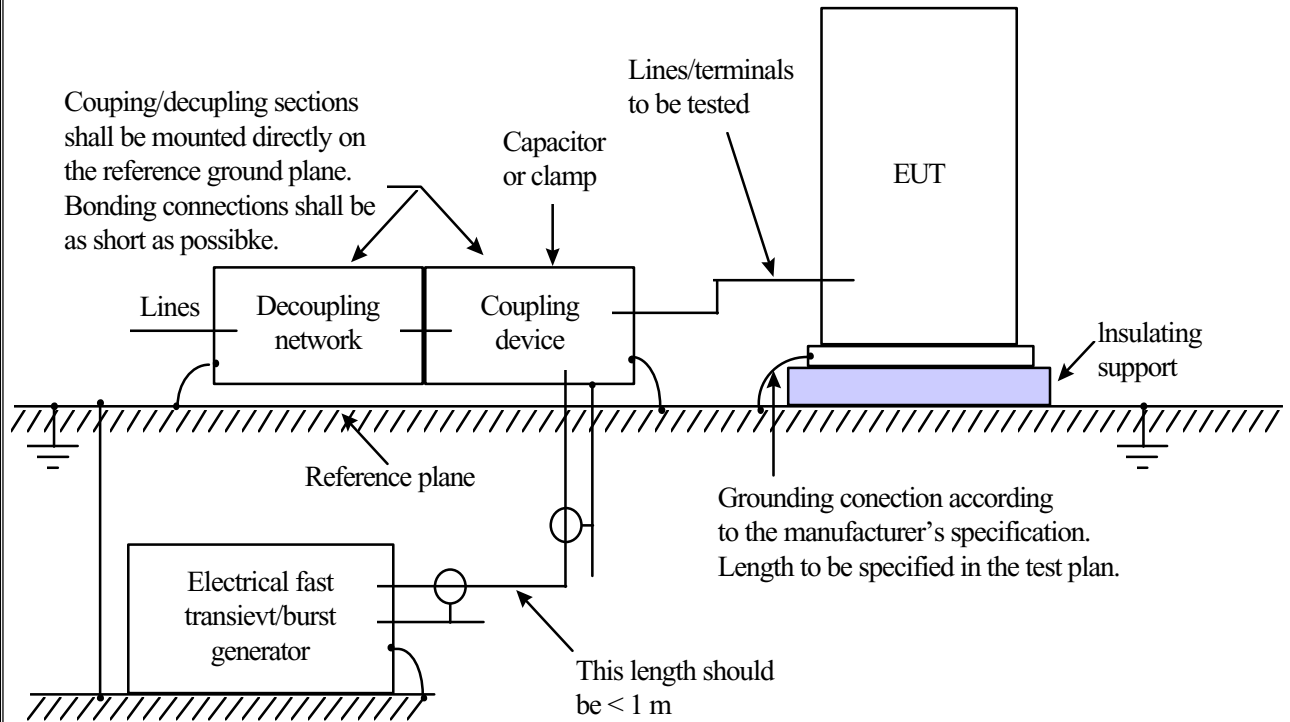

Block-diagram for electrical fast transient/burst immunity test

### 13.3 Fast Transient Burst Test Limits

Test levels

Open-circuit output test voltage ( $\pm 10\%$ ) and repetition rate of the impulses ( $\pm 20\%$ )				
Level	On power supply port, PE		On I/O (Input/Output) signal, data and control ports	
	Voltage peak kV	Repetition rate kHz	Voltage peak kV	Repetition rate kHz
1	0.5	5	0.25	5
2	1	5	0.5	5
3	2	5	1	5
4	4	2.5	2	5
x <sup>1)</sup>	Special	Special	Special	Special

<sup>1)</sup> "x" is an open level. The level has to be specified in the dedicated equipment specification.

## 13.4 Fast Transient Burst Test Setup Photo

< FRONT VIEW >



# PEP Testing Laboratory

12-3FI, No. 27-1, Lane 169, Kang-Ning St., Hsi-Chih,  
Taipei Hsien, Taiwan, R. O. C.

TEL: 886-2-26922097 FAX: 886-2-26956236

REPORT NO. : E940698

## 13.5 Fast Transient Burst Test Data

MODEL NO. : \_\_\_\_\_ UC232R \_\_\_\_\_

REGULATION : According to EN 61000-4-4 (1995+A2: 2001) Spec .

### TEST RESULT

Temperature : <u>28</u> degree .	Duration of tests : <u>1</u> min .						
Relative Humidity : <u>52</u> % RH .	Time between test : <u>60</u> second .						
Pulse : <u>5 / 50</u> ns .	AC Power : <u>230</u> Vac .						
Burst : <u>15 ms / 300 ms</u> .	DC Power : <u>N/A</u> Vdc .						
Voltage \ Polarity \ Test Point \ Mode \ Result	0.5 KV		1 KV		KV		
	+	-	+	-	+	-	
Power Line	L	/	/	P	P	/	/
	N	/	/	P	P	/	/
	G	/	/	P	P	/	/
Signal Line Clamp Test	/	/	/	/	/	/	

- Note : 1. "P" mean the EUT function is correct during the test .  
2. "F" ----- Fail  
3. "/" ----- no test

## 14. EN 61000-4-5 Surge Immunity Test

Test Standard	Model No.	Result
EN 61000-4-5	UC232R	B

**The test results shall be classified on the basis of the operating conditions and the functional specifications of the equipment under test , as in the following , unless different specifications are given by product committees or product specifications :**

***Performance Criterion :***

***A) normal performance within the specification limits ;***

***B) temporary degradation or loss of function or performance which is self-recoverable ;***

***C) temporary degradation or loss of function or performance which requires operator intervention or system reset ;***

## **14.1 Surge Immunity Test Description**

The task of the described laboratory test is to find the reaction of the EUT under specified operational conditions caused by surge voltages from switching and lightning effects at certain threat levels.

The following equipment is part of the test set-up :

- equipment under test (EUT);
- auxiliary equipment (AE);
- cables (of specified type and length);
- coupling device (capacitive or arrestors);
- test generator (combination wave generator, 1.2/50  $\mu$ s generator);
- decoupling network/protection devices;
- additional resistors, 10 ohm and 40 ohm

The surge is to be applied to the EUT MBS terminals via the capacitive coupling network. Decoupling networks are required in order to avoid possible adverse effects on equipment not under test that may be powered by the same lines and to provide sufficient decoupling impedance to the surge wave so that the specified wave may be developed on the lines under test .

### 14.2 Surge Immunity Test Setup

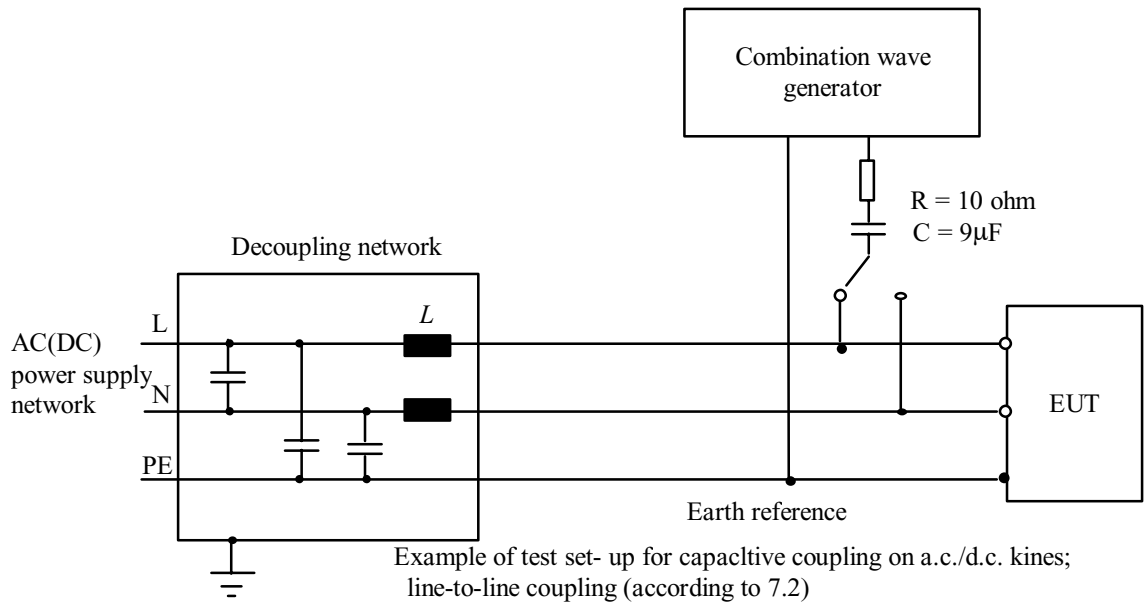
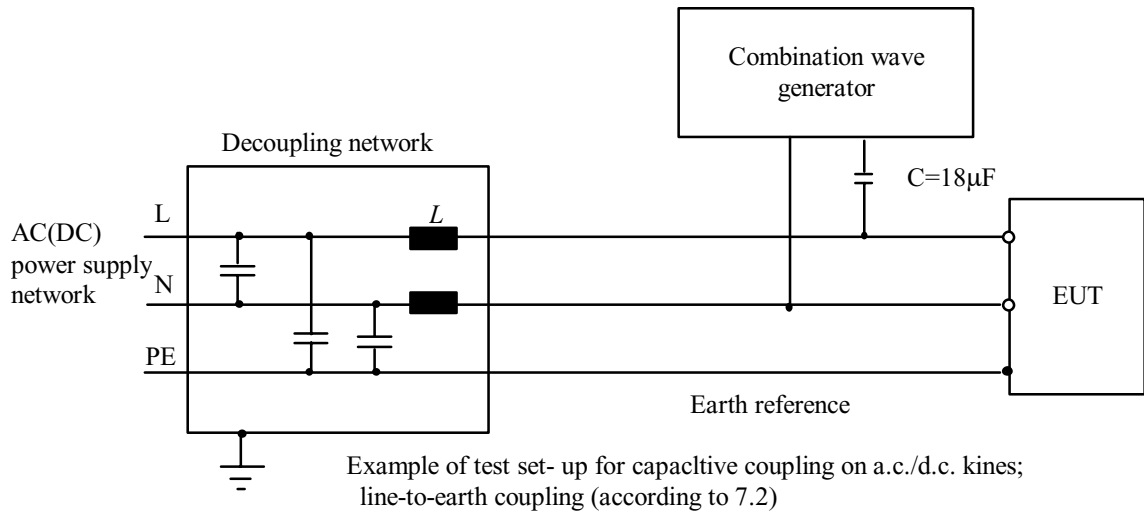

### 14.3 Surge Immunity Test Limits

The preferential range of test levels is given in table 1.

Table 1-Test levels

Level	Open-circuit test voltage +10 % - kV
1	0.5
2	1.0
3	2.0
4	4.0
x	Special

NOTE - x is an open class . The level can be specified in the product specification .

## PEP Testing Laboratory

12-3FI, No. 27-1, Lane 169, Kang-Ning St., Hsi-Chih,  
Taipei Hsien, Taiwan, R. O. C.

TEL: 886-2-26922097 FAX: 886-2-26956236

REPORT NO. : E940698

### 14.4 Surge Immunity Test Setup Photo

< FRONT VIEW >



# PEP Testing Laboratory

12-3FI, No. 27-1, Lane 169, Kang-Ning St., Hsi-Chih,  
Taipei Hsien, Taiwan, R. O. C.

TEL: 886-2-26922097 FAX: 886-2-26956236

REPORT NO. : E940698

## 14.5 Surge Immunity Test Data

MODEL NO : UC232R

TEST SETUP : According to EN 61000-4-5 (1995+A1: 2001)

### TEST RESULT

Temperature : <u>28</u> °C		Relative Humidity <u>52</u> %RH				
Waveform : <u>1,2 x 50 μs</u>		Test rate : <u>6</u> sec				
Times <u>5</u> times / each condition		AC power <u>230</u> VAC				
\Voltage\Mode\Polarity\Result		\Phase	0	90	180	270
1KV	Line	+	P	P	P	P
	Neutral	-	P	P	P	P
2KV	Line	+	/	/	/	/
	Neutral	-	/	/	/	/
2KV	Line	+	P	P	P	P
	Ground	-	P	P	P	P
	Neutral	+	P	P	P	P
	Ground	-	P	P	P	P

- Note : 1. " P " means the EUT function is correct during the test  
2. " / " no test

## **15. EN 61000-4-6 Immunity To Conducted Disturbances, Induced By Radio-Frequency Fields**

Test Standard	Model No.	Result
EN 61000-4-6	UC232R	A

**The test results shall be classified on the basis of the operating conditions and the functional specifications of the equipment under test , as in the following , unless different specifications are given by product committees or product specifications :**

***Performance Criterion :***

***A) normal performance within the specification limits ;***

***B) temporary degradation or loss of function or performance which is self-recoverable ;***

***C) temporary degradation or loss of function or performance which requires operator intervention or system reset ;***

## **15.1 Immunity To Conducted Disturbances, Induced By Radio-Frequency Fields Description**

The EUT shall be placed on an insulating support, 0.1 m above the ground reference plane. For table-top equipment, the ground reference plane may be placed on a table (see figure) .

On all cables to be tested, coupling and decoupling devices shall be inserted. The coupling and decoupling devices shall be placed on the ground reference plane, making direct contact with it at about 0.1 m to 0.3 m from the EUT. The cables between the coupling and decoupling devices and the EUT shall be as short as possible and shall not be bundled nor wrapped. height above the ground reference plane shall be between 30 mm and 50 mm.

If the EUT is provided with other earth terminals, they shall, when allowed, be connected to the ground reference plane through the coupling and decoupling network CDN-M1, (i.e. the AE port of the CDN-M1 is then connected to the ground reference).

If the EUT is provided with a keyboard or hand-held accessory, then the artificial hand shall be placed on this keyboard or wrapped around the accessory and connected to the ground reference plane.

Auxiliary equipment (AE) required for the defined operation of the EUT according to the specifications of the product committee, e.g. communication equipment, modem, printer, sensor, etc., as well as auxiliary equipment necessary for ensuring any data transfer and assessment of the functions, shall be connected to the EUT through coupling and decoupling devices. However, as far as possible the number of cables to be tested should be limited by restricting attention to the representative functions.

## 15.2 Immunity To Conducted Disturbances, Induced By Radio-Frequency Fields Setup

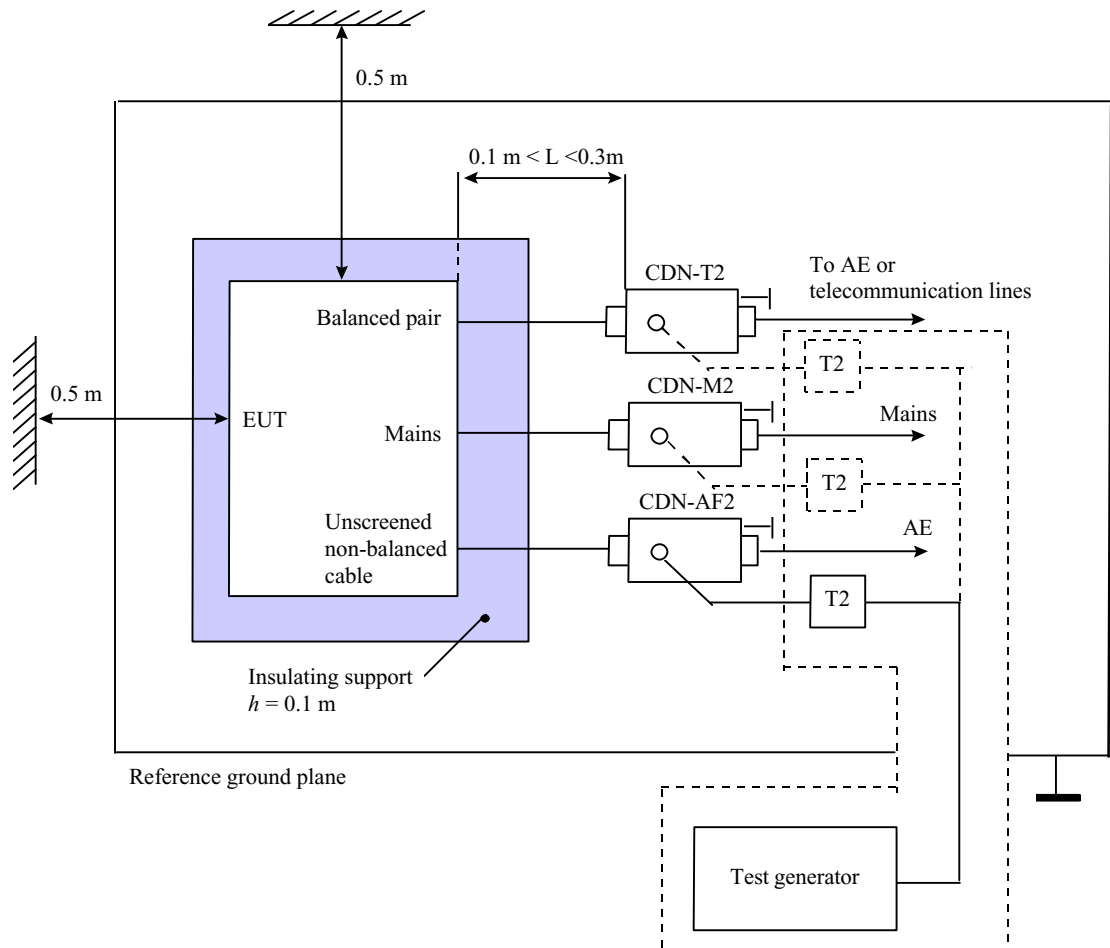

NOTE - The EUT clearance from any metallic obstacles shall be at least 0.5 m .  
 All non-excited input ports of the CDNs shall be terminated by 50 ohm loads .

Example of test set-up with a single-unit system  
 for class II safety equipment (see IEC 536)

### **15.3 Immunity To Conducted Disturbances, Induced By Radio-Frequency Fields Test Limits**

No tests are required for induced disturbances caused by electromagnetic fields coming from intentional RF transmitters in the frequency range 9 kHz to 150 kHz,  
The open-circuit test levels (e.m.f.) of the unmodulated disturbing signal, expressed in r.m.s., are given in table 1. The test levels are set at the EUT port of the coupling and decoupling devices. For testing of equipment, this signal is 80% amplitude modulated with a 1 kHz sine wave to simulate actual threats.

Table1 – Test levels

Frequency range 150 kHz – 80MHz		
Level	Voltage level (e.m.t.)	
	Uo [dB( $\mu$ V)]	Uo[V]
1	120	1
2	130	3
X <sup>1)</sup>	140	10
	special	

<sup>1)</sup> X is an open level.

## PEP Testing Laboratory

12-3FI, No. 27-1, Lane 169, Kang-Ning St., Hsi-Chih,  
Taipei Hsien, Taiwan, R. O. C.

TEL: 886-2-26922097 FAX: 886-2-26956236

REPORT NO. : E940698

### 15.4 Immunity To Conducted Disturbances, Induced By Radio-Frequency Fields Test Setup Photo

< FRONT VIEW >



# PEP Testing Laboratory

12-3FI, No. 27-1, Lane 169, Kang-Ning St., Hsi-Chih,  
Taipei Hsien, Taiwan, R. O. C.

TEL: 886-2-26922097 FAX: 886-2-26956236

REPORT NO. : E940698

## 15.5 Immunity To Conducted Disturbances, Induced By Radio-Frequency Fields Test Data

MODEL NO. : UC232R

REGULATION : EN 61000-4-6 (1996+A1: 2001)

TEST RESULT

Temperature : 28 degree , Relative Humidity : 52 % RH  
Start : 0.15 MHz , Stop : 80 MHz , Power : AC 230V  
Modulation : AM 80 % , 1kHz. ON (YES) , OFF (\_\_\_\_)  
Output impedance : 50 ohm , Source impedance : 150 ohm  
Performance criterion : A

Test Ports	Frequency(MHz) Range	EUT Condition	1V(rms) Field strength	3V(rms) Field strength
Input / Output a. c. power	0.15 - - - - - 80	NORMAL	/	P
Input / Output d. c.	0.15 - - - - - 80	NORMAL	/	/
Signal lines Control lines	0.15 - - - - - 80	NORMAL	/	/

Note : 1. " P " mean the EUT function is correct during the test.

2. " / " no test.

## 16. EN 61000-4-8 Power Frequency Magnetic Field Immunity Test

Test Standard	Model No.	Result
EN 61000-4-8	UC232R	A

(A) Test instruments :

- HAEFELY&TRENCH magnetic field tester MAG100.1
- HAEFELY&TRENCH coil with clamp 1m x 1m
- HAEFELY&TRENCH support with castors height 2m

(B) Laboratory reference conditions :

- Temperature : 28 °C
- relative humidity : 52 %
- atmospheric pressure : 95 kPa
- electromagnetic : 10 dB below the select test level

(C) Test level : level 1 , 1 A/m

**The test results shall be classified on the basis of the operating conditions and the functional specifications of the equipment under test , as in the following , unless different specifications are given by product committees or product specifications :**

***Performance Criterion :***

***A) normal performance within the specification limits ;***

***B) temporary degradation or loss of function or performance which is self-recoverable ;***

***C) temporary degradation or loss of function or performance which requires operator intervention or system reset ;***

## **16.1 Power Frequency Magnetic Field Immunity Test Description**

The magnetic fields to which equipment is subjected may influence the reliable operation of equipment and systems.

The following tests are intended to demonstrate the immunity of equipment when subjected to power frequency magnetic fields related to the specific location and installation condition of the equipment (e.g. proximity of equipment to the disturbance source).

The power frequency magnetic field is generated by power frequency current in conductors or, more seldom, from other devices (e.g. leakage of transformers) in the proximity of equipment.

As for the influence of nearby conductors, one should differentiate between:

- the current under normal operating conditions, which produces a steady magnetic field, with a comparatively small magnitude;
- the current under fault conditions which can produce comparatively high magnetic fields but of short duration, until the protection devices operate (a few milliseconds with fuses, a few seconds for protection relays).

The test with a steady magnetic field may apply to all types of equipment intended for public or industrial low voltage distribution networks or for electrical plants.

The test with short duration magnetic field related to fault conditions, requires test levels that differ from those for steady state conditions; the highest values apply mainly to equipment to be installed in exposed places of electrical plants.

The test field waveform is that of power frequency.

In many cases (household areas, sub-stations and power plant under normal conditions), the magnetic field produced by harmonics is negligible. However, in very special cases like heavy industrial areas (large power convectors, etc.) they occur, and will be considered in a future revision of this standard.

## 16.2 Power Frequency Magnetic Field Immunity Test Setup

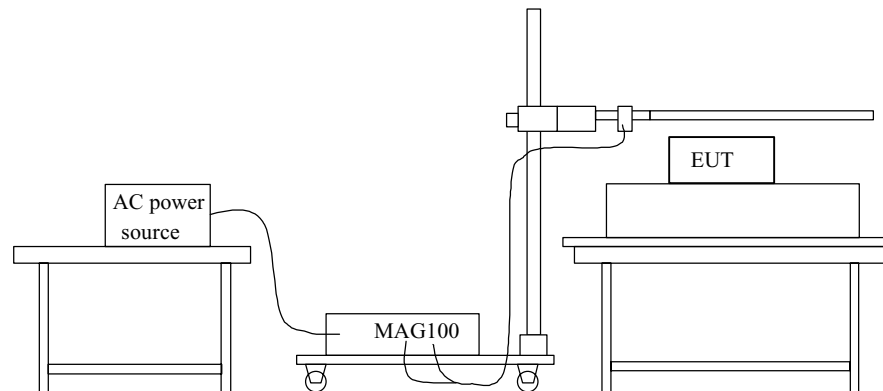

- Vertical magnetic field drawing

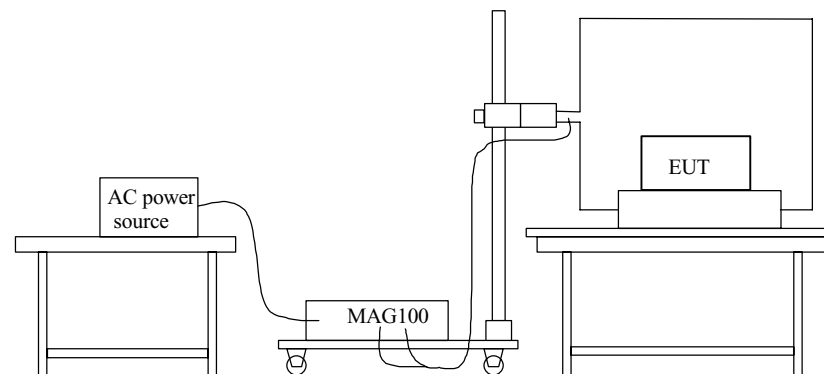

- Horizontal magnetic field drawing

### 16.3 Power Frequency Magnetic Field Immunity Test Limits

Table 1-Test levels for continuous field

Level	Magnetic field strength A/m
1	1
2	3
3	10
4	30
5	100
x <sup>1)</sup>	special

**NOTES**

1 – “x” is an open level. This level can be given in the product specification.

Table 2 – Test levels for short duration: 1 s to 3 s

Level	Magnetic field strength A/m
1	n.a. <sup>2)</sup>
2	n.a. <sup>2)</sup>
3	n.a. <sup>2)</sup>
4	300
5	1000
x <sup>1)</sup>	special

**NOTES**

1 – “x” is an open level. This level, as well the duration of the test, can be given in the product specification.

2 – “n.a.” = not applicable

## 16.4 Power Frequency Magnetic Field Immunity Test Setup Photos

< VERTICAL VIEW >



< HORIZONTAL VIEW >



## **17. EN 61000-4-11 Voltage Dips, Short Interruptions And Voltage Variations Immunity Tests**

### **17.1 Voltage Dips,short Interruptions And Voltage Variations Immunity Test Description**

Electrical and electronic equipment may be affected by voltage dips, short interruptions or voltage variations of Power Supply.

Voltage dips and short interruptions are caused by faults in the network, in installations or by a sudden large change of load. In certain cases, two or more consecutive dips or interruptions may occur. Voltage variations are caused by the continuously varying loads connected to the network. Before starting the test of a given equipment, a test plan shall be prepared.

It is recommended that the test plan shall comprise the following items :

- the type designation of the EUT;
- information on possible connections (plugs, terminals, etc.) and cables, and peripherals;
- input power port of equipment to be tested;
- representative operational modes of the EUT for the test;
- performance criteria used and defined in the technical specifications;
- operational mode(s) of equipment;
- description of the test set-up.

If the actual operating signal sources are not available to the EUT, they may be simulated.

For each test any degradation of performance shall be recorded.

The monitoring equipment should be capable of displaying the status of the operational mode of the EUT during and after the tests. After each group of tests a full functional check shall be performed.

## 17.2 Voltage Dips, short Interruptions And Voltage Variations Immunity Test Setup

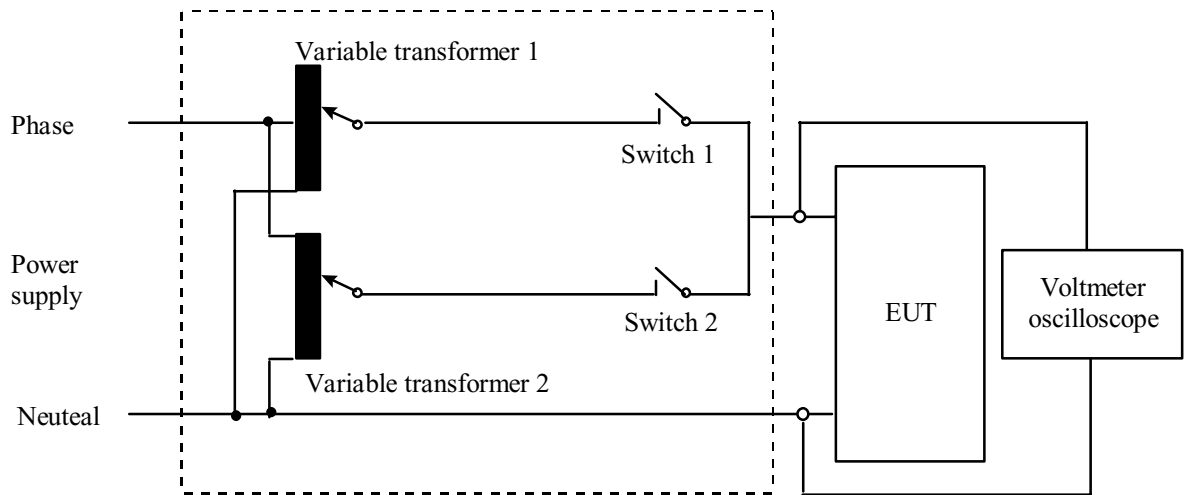

Schematic of test instrumentation for voltage dips and short interruptions using variable transformers and seitches

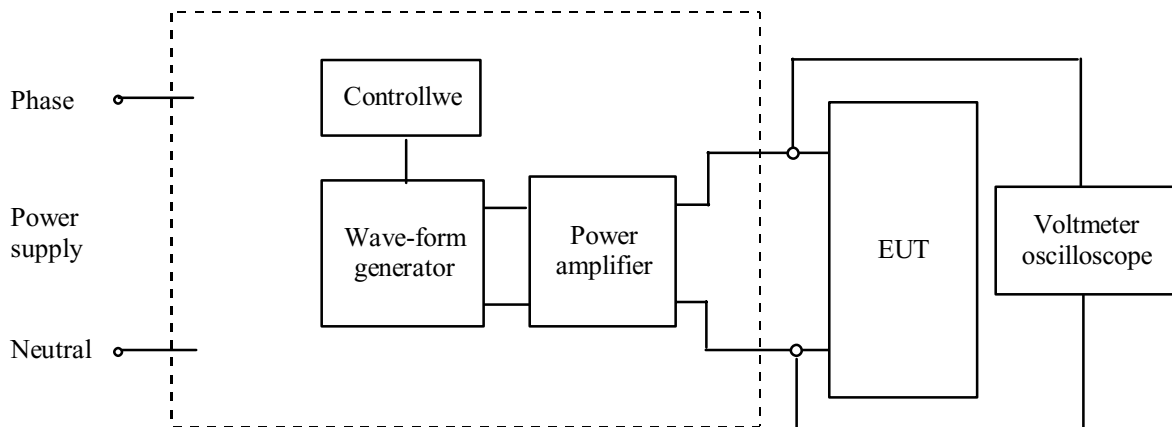

Schematic of test instrumentation for voltage dips, short interruptions and variations using power amplifier

### 17.3 Voltage Dips, short Interruptions And Voltage Variations Immunity Test Limits

Preferred test levels and durations for  
 voltage dips and short interruptions

Test level  % $U_T$	Voltage dip and short interruptions  % $U_T$	Duration (in period)
0	100	0.5*
40	60	1
70	30	5
		10
		25
		50
		x

\* For 0.5 period, the test shall be made in positive and negative polarity, i.e. starting at 0° and 180°, respectively .

**NOTES**

- 1 One or more of the above test levels and durations may be chosen .
- 2 If the EUT is tested for voltage dips of 100%, it is generally unnecessary to test for other levels for the same durations. However, for some cases (safeguard systems or electromechanical devices) it is not true. The product specification or product committee shall give an indication of the applicability of this note .
- 3 "x" is an open duration. This duration can be given in the product specification. Utilities in Europe have measured dips and short interruptions of duration between 1/2 a period and 3000 periods, but duration less than 50 periods are most common.
- 4 Any duration may apply to any test level .

## 17.4 Voltage Dips, short Interruptions And Voltage Variations Test Setup Photo

< FRONT VIEW >



# PEP Testing Laboratory

12-3FI, No. 27-1, Lane 169, Kang-Ning St., Hsi-Chih,  
Taipei Hsien, Taiwan, R. O. C.

TEL: 886-2-26922097 FAX: 886-2-26956236

REPORT NO. : E940698

## 17.5 Voltage Dips, short Interruptions And Voltage Variations Immunity Test Data

MODEL NO. : \_\_\_\_\_ UC232R \_\_\_\_\_

REGULAR : EN 61000-4-11 (1994+A1: 2001)

TEST RESULT : Test Voltage **230Vac**

	Test Level %U <sub>T</sub>	Duration ( ms )	Performance Criterion
Voltage dips	>95	10	A
	30	500	B
Voltage interruptions	>95	5000	C

U<sub>T</sub> is the rated voltage for the equipment.

## 18. Labelling Requirement, Warning



1. The vertical size is 5mm.
2. The mark will be placed in a visible spot on the outside of the equipment, but in cases where that is impractical, it may be included on the packaging and/or documentation.

ITE is subdivided into two categories denoted class A ITE and class B ITE.

### **Class A ITE**

Class A ITE is a category of all other ITE which satisfies the Class A ITE limits but not the Class B ITE limits. Such equipment should not be restricted in its sale but the following warning shall be included in the instructions for use :

#### **Warning**

This is a Class A product. In a domestic environment this product may cause radio interference in which case the user may be required to take adequate measures.

### **Class B ITE**

Class B ITE is a category of apparatus which satisfies the class B ITE disturbance limits.

Class B ITE is intended primarily for use in the domestic environment and may include:

- equipment with no fixed place of use; for example, portable equipment powered by built-in batteries;
- telecommunication terminal equipment powered by a telecommunication network;
- personal computers and auxiliary connected equipment.

**PEP Testing Laboratory**

12-3FI, No. 27-1, Lane 169, Kang-Ning St., Hsi-Chih,

Taipei Hsien, Taiwan, R. O. C.

TEL: 886-2-26922097 FAX: 886-2-26956236

REPORT NO. : E940698

**19. The List of Test Instruments**

<b>Test Mode</b>	<b>Instrument</b>	<b>Model No.</b>	<b>Serial No.</b>	<b>Next Cal. Date</b>	<b>Cal. Interval</b>
<b>Conduction (No.2)</b>	Advantest Spectrum	R3261A	91720076	June 08, 2006	1Year
	R & S LISN(EUT)	ESH2-Z5	831886/004	Apr. 24, 2006	1Year
	Kyoritsu LISN(2nd)	KNW-242	8-837-7	N/A	N/A
	RF Cable	No.4	N/A	Feb. 18, 2006	1Year
<b>Radiation (OP No.3)</b>	R & S Receiver	ESBI	845658/003	July 27, 2006	1Year
	Schaffner Pre-Amp.	CPA-9232	1012	Aug. 20, 2006	1Year
	SCHWARZBECK Antenna	9161	9161-4051	May 05, 2006	1Year
	COM-Power Horn Ant.	AH-118 (1GHz~18GHz)	10095	May 20, 2006	1Year
	RF Cable	No.2	N/A	Feb. 18, 2006	1Year
	SCHWARZBECK Precision Dipole Ant.	VHAP (30MHz~1GHz)	970+971 953+954	June 27, 2006	3Year
	R & S Signal Generator	SMY01	829846/038	Feb. 15, 2007	2Year

# PEP Testing Laboratory

12-3FI, No. 27-1, Lane 169, Kang-Ning St., Hsi-Chih,  
Taipei Hsien, Taiwan, R. O. C.

TEL: 886-2-26922097 FAX: 886-2-26956236

REPORT NO. : E940698

	Test item	Instrument	Model No.	Serial No.	Next Cal. Date	Cal. Interval
EMS (NO.2)	-4-2	(EMC-PARTNER) Transient Tester	TRA-2000/N6	456	Aug. 12, 2006	1Year
	-4-4	(EMC-PARTNER) ESD Test System	TRA1Z03B	399	Aug. 12, 2006	1Year
	-4-5	(EMC-PARTNER) EFT/B Clamp	TAR1Z03B	CNEFT 1000-268	Aug. 12, 2006	1Year
	-4-8	(EMC-PARTNER) Magnetic Field Loop antenna	MF-1000	MF 1000-169	Aug. 12, 2006	1Year
	-4-11	(EMC-PARTNER) Magnetic Field Loop antenna	MF-1000	MF 1000-169	Aug. 12, 2006	1Year
	-4-6	CONDUCTED IMMUNITY	CIT-10 /102C3117	102C3117	July 24, 2006	2Years
	-3-2	(EMC-PARTNER) Harmonic/ Flicker	HAR-1000	66	July 22, 2006	2Years
	-3-3	(EMC-PARTNER) Harmonic/ Flicker	HAR-1000	66	July 22, 2006	2Years
	-4-3	(Amplifier & Research) Power Amplifier	100W1000M11	25616	May 08, 2006	2Years
	-4-3	(Amplifier & Research) Power Meter	PM2002	N/A	May 08, 2006	2Years
	-4-3	(Amplifier & Research) Field Monitor	FM5510	25355	May 08, 2006	2Years
	-4-3	(Amplifier & Research) Field Probe	FP5000	25339	May 08, 2006	2Years
	-4-3	(Amplifier & Research) Direct Coupler	DC6080	N/A	May 08, 2006	2Years
-4-3	(Boonton) Power Sensor	51011-EMC	31094	May 08, 2006	2Years	
-4-3	(Boonton) Power Sensor	31011-EMC	31078	May 08, 2006	2Years	

## 20. EUT Photos

MODEL NO. : UC232R

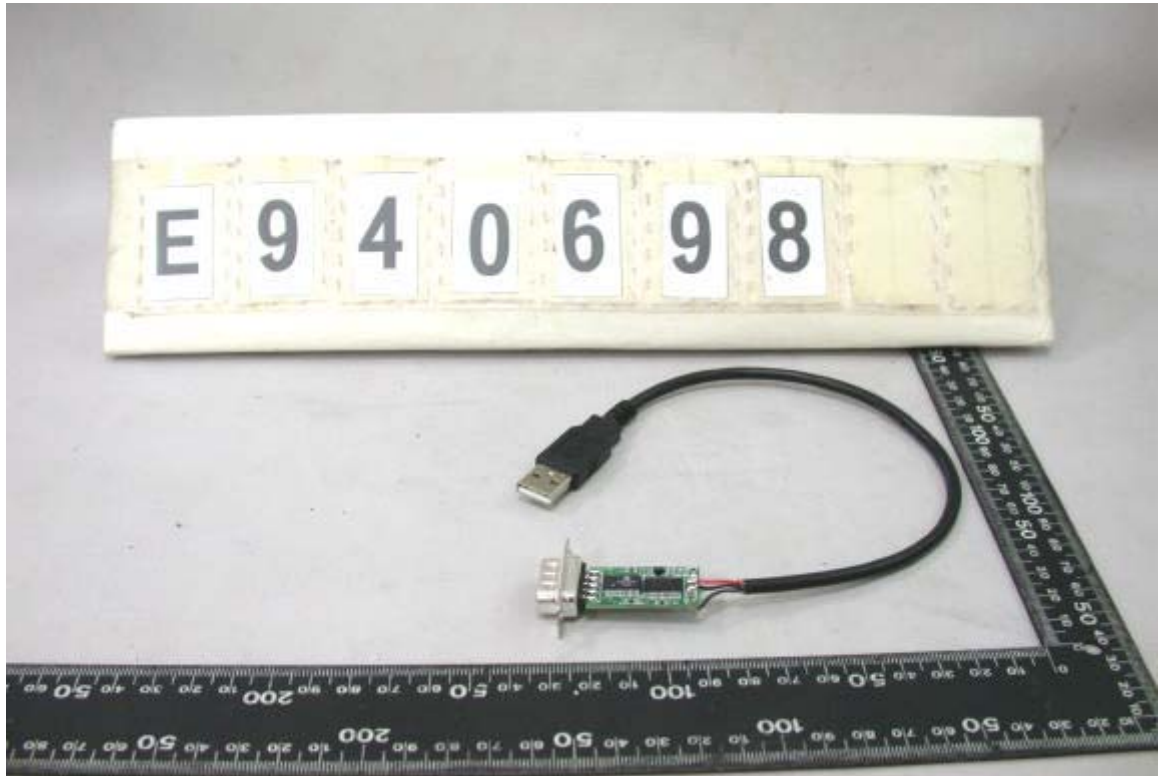

**PEP Testing Laboratory**

12-3FI, No. 27-1, Lane 169, Kang-Ning St., Hsi-Chih,  
Taipei Hsien, Taiwan, R. O. C.

TEL: 886-2-26922097 FAX: 886-2-26956236

REPORT NO. : E940698

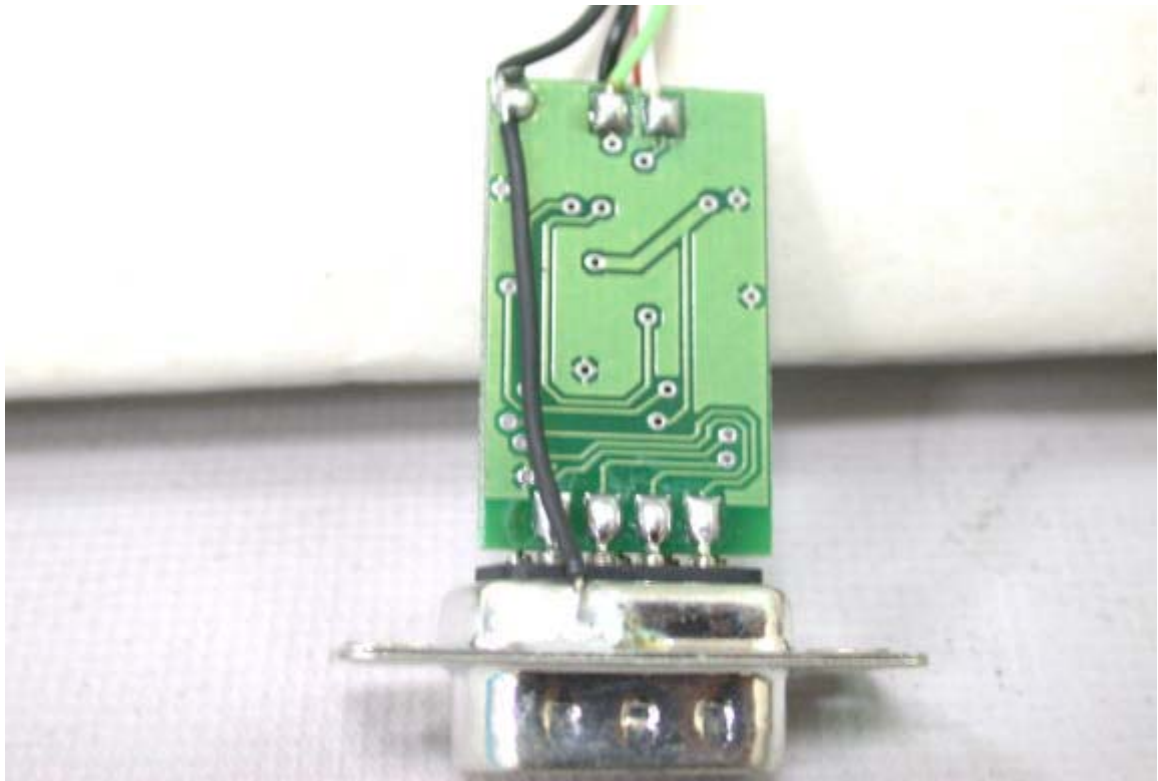

# VERIFICATION

## of conformity with European EMC Directive

No. E940698

*Document holder:* **FUTURE TECHNOLOGY DEVICES INTERNATIONAL LTD.**

*Type of equipment:* **Chipi**

*Type designation:* **UC232R**

A sample of the equipment has been tested for CE-marking according to the EMC Directive, 89/336/EEC. & 92/31/EEC & 93/68/EEC *Standard(s) used for showing compliance with the essential requirements of the directive:*

*EMC Standard(s):*

EN 55022: 1998+A1: 2000+A2: 2003

EN 61000-3-2: 2000

EN 61000-3-3:1995+A1: 2001

Class B

EN 55024: 1998+A1:  
2001+A2:2003

EN 61000-4-2: 1995+A1:  
1998+A2:2001

EN 61000-4-3: 2002+ A1:2002

EN 61000-4-4: 1995+A2: 2001

EN 61000-4-5: 1995+A1: 2001

EN 61000-4-6: 1996+A1: 2001

EN 61000-4-8: 1993+A1: 2001

EN 61000-4-11: 1994+A1: 2001

*Performance Criterion*

B

A

B

B

A

A

The referred test report(s) show that the product fulfills the requirements in the EMC Directive for CE marking. On this basis, together with the manufacturer's own documented production control, the manufacturer (or his European authorized representative) can in his EC Declaration of Conformity verify compliance with the EMC Directive.

Signed for and on behalf of  
**PEP Testing Laboratory**



*M. Y. Tsui*

Date: SEP. 26, 2005

M. Y. Tsui / President

# Declaration of Conformity

The following

**Applicant** : **FUTURE TECHNOLOGY DEVICES INTERNATIONAL LTD.**

**Equipment** : **Chipi**

**Model No.** : **UC232R**

**Report No.** : **E940698**

is herewith confirmed to comply with the requirements set out in the Council Directive on the Approximation of the Laws of the Member States relating to Electromagnetic Compatibility(89/336/EEC) and the amendments in the Council Directive 92/31/EEC, 93/68/EEC.

For the evaluation of above mentioned Directives, the following standards were applied:

- 1) EN 55022: 1998+A1 : 2000+A2 : 2003 Class B
- 2) EN 61000-3-2 : 2000
- 3) EN 61000-3-3 : 1995+A1: 2001
- 4) EN 55024 : 1998+A1 : 2001+A2 : 2003  
    EN 61000-4-2 : 1995+A1: 1998 +A2: 2001  
    EN 61000-4-3 : 2002+A1: 2002  
    EN 61000-4-4 : 1995+A2: 2001  
    EN 61000-4-5 : 1995+A1: 2001  
    EN 61000-4-6 : 1996+A1: 2001  
    EN 61000-4-8 : 1993+A1: 2001  
    EN 61000-4-11 : 1994+A1: 2001

The following manufacturer is responsible for this declaration:

**FUTURE TECHNOLOGY DEVICES INTERNATIONAL LTD.**

**373 SCOTLAND ST., GLASGOW  
G58QB SCOTLAND U. K.**

U. K. / SEP. 26, 2005

Place and Date

\_\_\_\_\_  
Signature of responsible Person