



Application Note

AN_206

FT1248 1-BIT SPI

Version 1.0

Issue Date: 2012-02-09

FT1248 is a proprietary FTDI interface that allows for a synchronous parallel/serial interface where the data bus may be 1, 2, 4 or 8 bit wide. This application note describes how the interface may be used with an SPI master in 1-bit data mode.

Use of FTDI devices in life support and/or safety applications is entirely at the user's risk, and the user agrees to defend, indemnify and hold FTDI harmless from any and all damages, claims, suits or expense resulting from such use.

Future Technology Devices International Limited (FTDI)

Unit 1, 2 Seaward Place, Glasgow G41 1HH, United Kingdom

Tel.: +44 (0) 141 429 2777 Fax: + 44 (0) 141 429 2758

Web Site: <http://ftdichip.com>

Copyright © 2012 Future Technology Devices International Limited

Table of Contents

1	Introduction	2
1.1	Overview	2
2	Example Circuit	3
3	FT1248 Interface Description.....	4
3.1	Determining the Dynamic Bus Width	5
3.2	Supported Commands on the FT1248 Interface.....	6
3.3	LSB or MSB Selection	7
3.4	Clock Phase/Polarity	7
3.4.1	CPHA = 1.....	7
3.5	FT1248 Timing.....	9
4	Contact Information.....	11
	Appendix A – References.....	12
	Document References.....	12
	Acronyms and Abbreviations.....	12
	Appendix B – List of Tables & Figures	13
	List of Tables	13
	List of Figures	13
	Appendix C – Revision History	14

1 Introduction

FT1248 is a proprietary FTDI interface currently available in FT220X, FT221X and FT232H devices, that allows for a synchronous parallel/serial interface where the data bus may be 1, 2, 4 or 8 bit wide. This application note describes how the interface may be used with an SPI (Serial Peripheral Interface) master in 1-bit data mode.

1.1 Overview

SPI is a recognized industry standard interface for connecting devices in an electronic system. The interface operates on a slave / host basis where one host can access many slaves by addressing each device on the bus with a chip select signal. Data is sent and received synchronously with a clock signal provided by the SPI host. Typically an SPI system will use separate data lines for input and output, but some hosts have a bi-directional data line which would be compatible with the FT1248 1-bit interface.

2 Example Circuit

The diagram below shows how the FT220X device could be used as an SPI slave in the 1-bit data configuration.

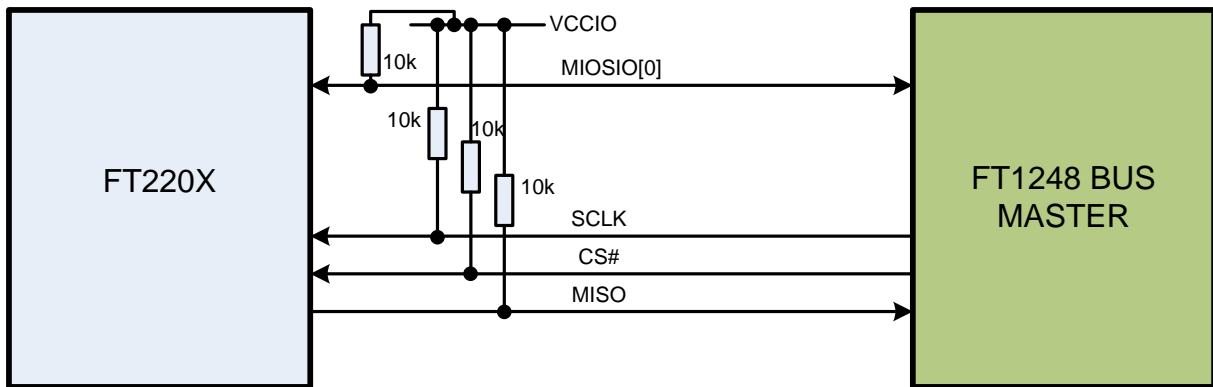

Figure 2.1 FT220X Configured for 1-bit Data

The FT220X is the slave device and the external FPGA/MCU is the bus master. The FT220X will auto detect the bus width from the initial command byte sent by the bus master. The other MIOSIO[x] data lines that are not required on the FT220X may be left un-terminated as an internal pull-up ensures the device detects a logic 1.

MIOSIO[0] is the bi-directional data line, which the master must read or write to.

SCLK is the clock from the master to the FT220X. This may be up to 1MHz.

CS# is the active low chip select to enable the FT220X FT1248 interface.

MISO is an output from the FT220X that should be read to obtain the status from the FT1248 interface. The status advises the bus master if the device can accept more data or if data is available to be read.

3 FT1248 Interface Description.

FT1248 1-bit mode it requires 8 clock cycles to get 8 data bits in and 8 clock cycles to get 8 data bits out. Although requiring extra clock cycles compared to using the interface in 8-bit mode it is the most efficient in terms of pin count, required to connect it to the host.

In the FT1248 there are 3 distinct phases:

While CS# is inactive, the FT1248 reflects the status of the write buffer and read buffers within the FT220X/FT221X on the MIOSIO[0] and MISO wires respectively. The buffers are 512 Bytes each and the status will reflect if at least one byte of space is available for the external device to write to and whether at least one byte is available to be read by the external device.

Additionally, the FT1248 slave supports multiple slave devices where a master can communicate with multiple SPI slave devices. When the slave is sharing buses with other SPI slave devices, the write and read buffer status cannot be reflected on the MIOSIO[0] and MISO wires during CS# inactivity as this would cause bus contention. Therefore, it is possible for the user to select whether they wish to have the buffer status switched on or off during inactivity.

(This setting may be applied in the internal MTP memory with FT_PROG).

When CS# is active a command/bus size phase occurs first. Following the command phase is the data phase, for each data byte transferred the FT1248 slave drives an ACK/NAK status onto the MISO wire. The master can send multiple data bytes so long as CS# is active, if an unsuccessful data transfer occurs, i.e. a NAK happens on the MISO wire then the master should immediately abort the transfer by de-asserting CS#.

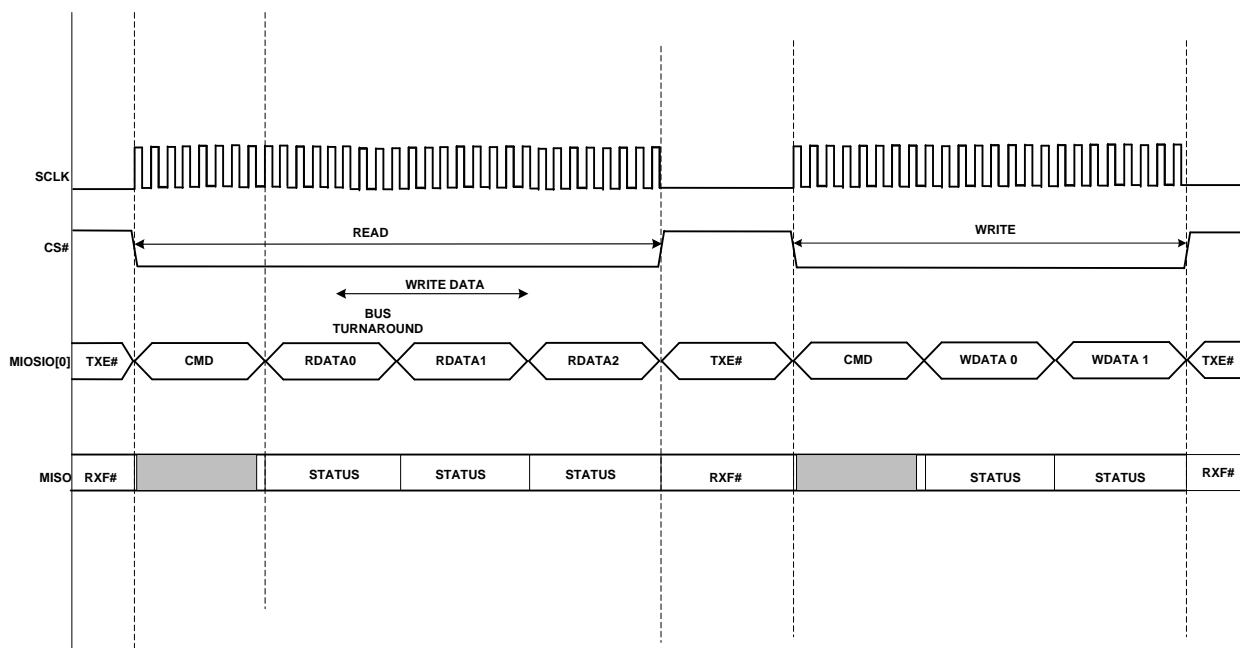

Figure 3.1: FT1248 Basic Waveform Protocol.

3.1 Determining the Dynamic Bus Width

The bus width is dynamic. In order for the FT220X/FT221X, in FT1248 mode, to determine the bus width within the command phase, the bus width is encoded along with the actual commands on the first active clock edge when CS# is active and has a data width of 4-bits.

If any of the MIOSIO[3:2] signals are driven low by the external host then the data transfer width equals 4-bits

If MIOSIO[1] signal is driven low by the external host then the data transfer width equals 2-bits

Else the bus width is defaulted to 1-bit

In order to successfully decode the bus width, all MIOSIO signals must have pull up resistors. By default, all MIOSIO signals shall be seen by the FT220X/FT221X in FT1248 mode as logic '1' from the internal resistors. This means that when a FT1248 master does not wish to use certain MIOSIO signals, the slave (FT220X / FT221X) is still capable of determining the requested bus width since any unused MIOSIO signals shall be pulled up by default.

The remaining bits used during the command phase are used to contain the command itself which means that it is possible to define up to 16 unique commands.

	LSB							MSB
	CMD[3]	BWID 2-bit	BWID 4-bit	CMD[2]	BWID 8-bit	CMD[1]	CMD[0]	X
	0	1	2	3	4	5	6	7
1-bit Bus Width	CMD[3]	X	X	CMD[2]	X	CMD[1]	CMD[0]	X
	0	1	2	3	4	5	6	7
2-bit Bus Width	CMD[3]	0	X	CMD[2]	X	CMD[1]	CMD[0]	X
	0	1	2	3	4	5	6	7
4-bit Bus Width	CMD[3]	X	0	CMD[2]	X	CMD[1]	CMD[0]	X
	0	1	2	3	4	5	6	7

Figure 3.2: FT1248 Command Structure

3.2 Supported Commands on the FT1248 Interface

The FT1248 interface can accept and decode up to 16 unique commands. At this time only 9 unique commands are implemented as shown below.

Command	Identifier	Description
write	0x00	Write request command
read	0x01	Read request command
read modem status	0x02	Read modem status command, users may wish to emulate modem status control. A RMS command returns status bits RTS and DTR
write modem status	0x03	Write modem status command, users may wish to emulate modem status control. A WMS command allows users to set status bits: DCD, RI, DSR, CTS
write buffer flush	0x04	Write buffer flush request – This command is used to indicate to the FT1248 slave that its write buffers should be flushed rather than wait for any latency timers to expire. If this command is received the FT1248 block will flag the upstream controllers (USB FIFOs etc) to flush their write buffers regardless of what content is present in the FT1248 write buffer
address eeprom	0x05	Address EEPROM command sets the address users wish to write or read from
write eeprom	0x06	Write EEPROM command sets the write data to be written into the EEPROM
read eeprom	0x07	Read EEPROM command reads
read usb status	0x08	Read USB Status: 00 = suspended, 01 = default, 10 = addressed, 11 = configured
Reserved	0x09 – 0xF	Unused Commands

Table 3.1: FT1248 Commands

3.3 LSB or MSB Selection

The data can be sent/received Least Significant Bit First (LSB) or Most Significant Bit First (MSB). To determine which mode is used by the FT1248 interface of the FT220X the MTP memory must be set.

This may be selected with FT_PROG.

3.4 Clock Phase/Polarity

The FT1248 slave does not need to have any knowledge of clock rate as this is supplied by the FT1248 master. However the relationship between clock and data needs to be controllable, to allow the slave to operate in the same way as the master such that data is correctly driven and sampled on the correct clock phases. By configuring the polarity and phase of CLK with respect to the data it is possible to match the FT1248 (SPI) master.

There are 4 possible modes which are determined by the Clock Polarity (CPOL) and Clock Phase (CPHA) signals. The different combinations of these signals are commonly referred to as modes, see Table 3.2 below. For the FT1248 slave, only 2 of these 4 modes are supported. CPHA will always be set to 1 in the FT1248 slave because data is available or driven on to MIOSIO wires on the first clock edge after CS# is active and is therefore sampled on the trailing edge of the first clock pulse. When CPHA equals 0, it means data must be available or driven onto the MIOSIO wires on the first leading edge of the clock after CS# is active. However, during this period between CS# becoming active and the first leading clock edge is when the MIOSIO wires are being "turned around" as when CS# is inactive the FT1248 slave is driving the write buffer status. Supporting CPHA = 0 would result in bus contention and therefore, shall not be supported.

Mode	CPOL	CPHA	Supported
0	0	0	NO
1	0	1	YES
2	1	0	NO
3	1	1	YES

Table 3.2: CPOL & CPHA Mode Numbers

When CPOL is 1, the idle state of the clock is high. When CPOL is 0, the idle state of the clock is low. It should be noted that clock phase and polarity need to be identical for the master and attached slave device.

3.4.1 CPHA = 1

When CPHA is set to '1', the first edge after CS# goes low will be used to shift (or drive) the first data bit onto MIOSIO. Every odd numbered edge after this will shift out the next data bit. Incoming data will be sampled on the second or trailing SCLK edge and every even edge thereafter.

Figure 3.3 shows this for both CPOL = 0 and CPOL = 1.

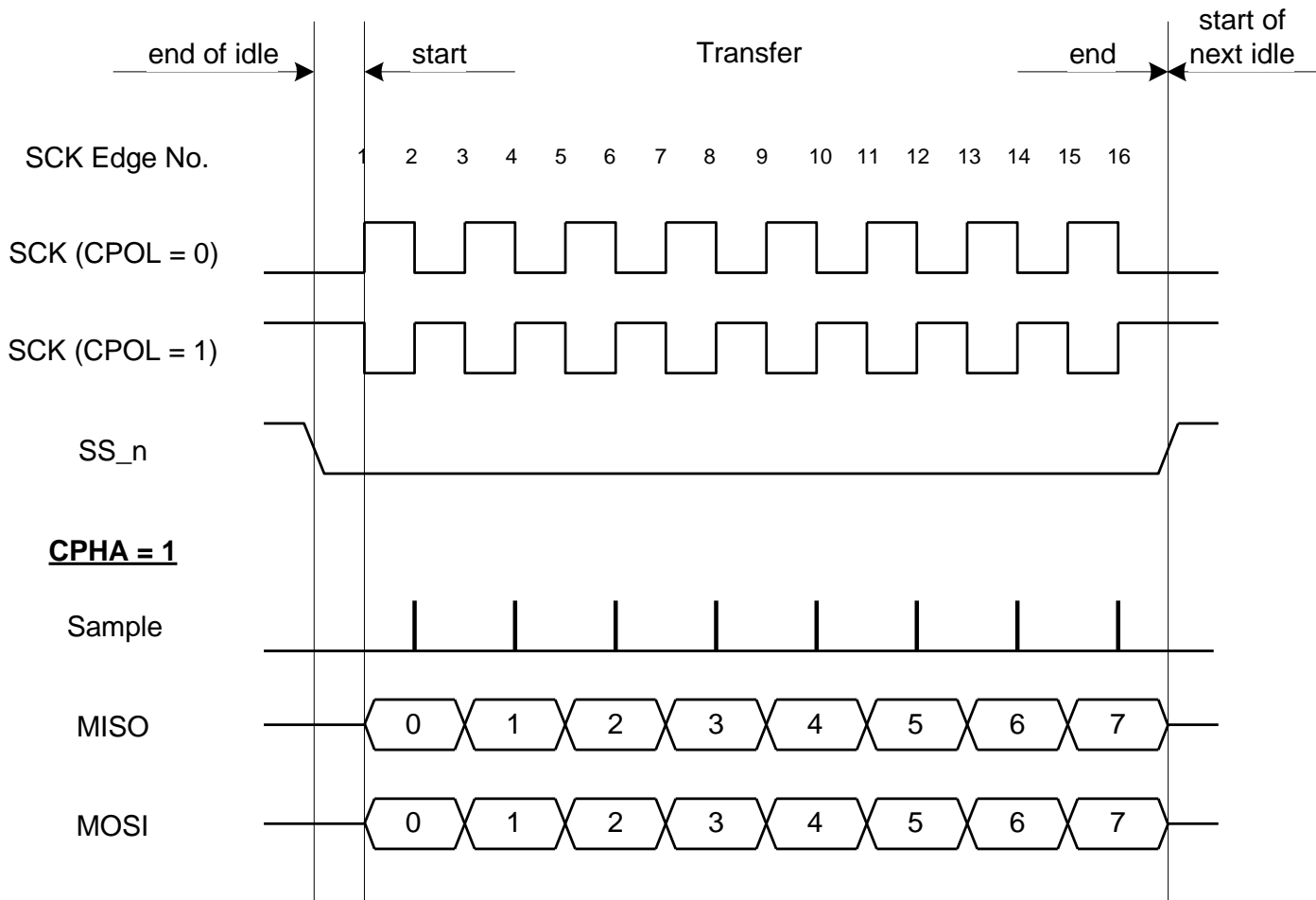

Figure 3.3: FT1248 Clock Format CPHA = 1

Note: The CPOL value may be selected in the MTP memory. This may be done with FT_PROG.

Note: Further information on this interface can be found in AN_167_FT1248 Parallel Serial Interface Basics from the FTDI website www.ftdichip.com.

3.5 FT1248 Timing

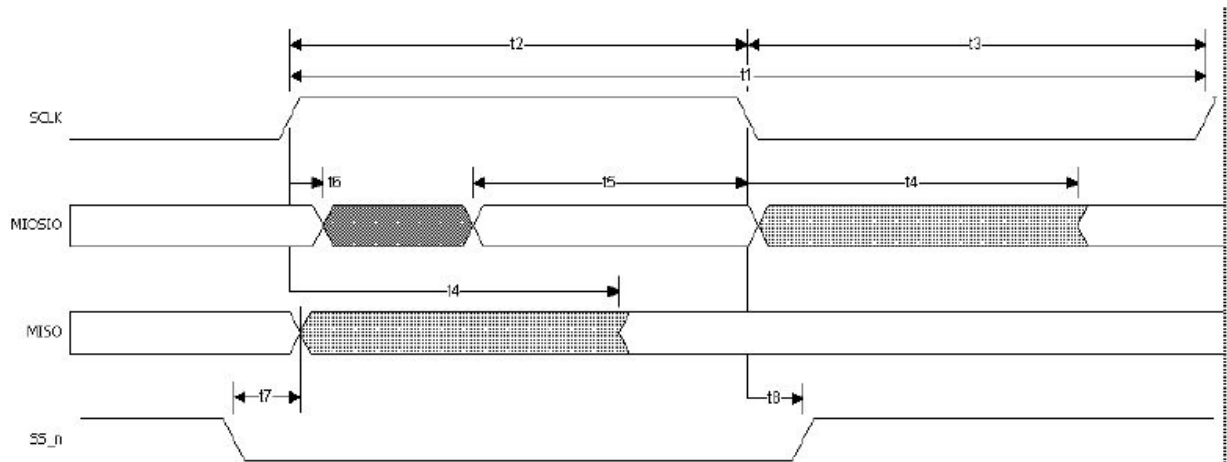

Figure 3.4: FT1248 Clock Format CPHA = 1

The timings will vary depending on VCCIO.

	Min (ns)	Typical (ns)	Max (ns)	Description
T1		83.33ns		SCLK Period
T2		41.67ns		SCLK HIGH
T3		41.67ns		SCLK LOW
T4		1	30	SCLK rising or falling driving edge to MIO_SIO/MISO
T5		25		MIO_SIO setup time to rising or falling sample SCLK edge
T6		3		MIO_SIO hold time from rising or falling sample SCLK edge
T7		5		SS_n setup time to rising or falling SCLK edge
T8		5		SS_n hold time from rising or falling sample SCLK edge

Table 3.3: 1V8 VCCIO timings

	Min (ns)	Typical (ns)	Max (ns)	Description
T1		83.33ns		SCLK Period
T2		41.67ns		SCLK HIGH
T3		41.67ns		SCLK LOW
T4		1	15	SCLK rising or falling driving edge to MIOSIO/MSIO
T5		22		MIOSIO setup time to rising or falling sample SCLK edge
T6		1		MIOSIO hold time from rising or falling sample SCLK edge
T7		5		SS_n setup time to rising or falling SCLK edge
T8		5		SS_n hold time from rising or falling sample SCLK edge

Table 3.4: 2V5 VCCIO timings

	Min (ns)	Typical (ns)	Max (ns)	Description
T1		83.33ns		SCLK Period
T2		41.67ns		SCLK HIGH
T3		41.67ns		SCLK LOW
T4		1	10	SCLK rising or falling driving edge to MIOSIO/MSIO
T5		20		MIOSIO setup time to rising or falling sample SCLK edge
T6		0		MIOSIO hold time from rising or falling sample SCLK edge
T7		5		SS_n setup time to rising or falling SCLK edge
T8		5		SS_n hold time from rising or falling sample SCLK edge

Table 3.5: 3V3 VCCIO timings

4 Contact Information

Head Office – Glasgow, UK

Future Technology Devices International Limited
Unit 1, 2 Seaward Place, Centurion Business Park
Glasgow G41 1HH
United Kingdom
Tel: +44 (0) 141 429 2777
Fax: +44 (0) 141 429 2758

E-mail (Sales) sales1@ftdichip.com
E-mail (Support) support1@ftdichip.com
E-mail (General Enquiries) admin1@ftdichip.com

Branch Office – Hillsboro, Oregon, USA

Future Technology Devices International Limited
(USA)
7235 NW Evergreen Parkway, Suite 600
Hillsboro, OR 97123-5803
USA
Tel: +1 (503) 547 0988
Fax: +1 (503) 547 0987

E-Mail (Sales) us.sales@ftdichip.com
E-Mail (Support) us.support@ftdichip.com
E-Mail (General Enquiries) us.admin@ftdichip.com

Branch Office – Taipei, Taiwan

Future Technology Devices International Limited
(Taiwan)
2F, No. 516, Sec. 1, NeiHu Road
Taipei 114
Taiwan, R.O.C.
Tel: +886 (0) 2 8791 3570
Fax: +886 (0) 2 8791 3576

E-mail (Sales) tw.sales1@ftdichip.com
E-mail (Support) tw.support1@ftdichip.com
E-mail (General Enquiries) tw.admin1@ftdichip.com

Branch Office – Shanghai, China

Future Technology Devices International Limited
(China)
Room 408, 317 Xianxia Road,
Shanghai, 200051
China
Tel: +86 21 62351596
Fax: +86 21 62351595

E-mail (Sales) cn.sales@ftdichip.com
E-mail (Support) cn.support@ftdichip.com
E-mail (General Enquiries) cn.admin@ftdichip.com

Web Site

<http://ftdichip.com>

System and equipment manufacturers and designers are responsible to ensure that their systems, and any Future Technology Devices International Ltd (FTDI) devices incorporated in their systems, meet all applicable safety, regulatory and system-level performance requirements. All application-related information in this document (including application descriptions, suggested FTDI devices and other materials) is provided for reference only. While FTDI has taken care to assure it is accurate, this information is subject to customer confirmation, and FTDI disclaims all liability for system designs and for any applications assistance provided by FTDI. Use of FTDI devices in life support and/or safety applications is entirely at the user's risk, and the user agrees to defend, indemnify and hold harmless FTDI from any and all damages, claims, suits or expense resulting from such use. This document is subject to change without notice. No freedom to use patents or other intellectual property rights is implied by the publication of this document. Neither the whole nor any part of the information contained in, or the product described in this document, may be adapted or reproduced in any material or electronic form without the prior written consent of the copyright holder. Future Technology Devices International Ltd, Unit 1, 2 Seaward Place, Centurion Business Park, Glasgow G41 1HH, United Kingdom. Scotland Registered Company Number: SC136640

Appendix A – References

Document References

[FT232H Data Sheet](#)

[FT220X Data Sheet](#)

[FT221X Data Sheet](#)

[AN_167_FT1248_Parallel_Serial_Interface_Basics](#)

Acronyms and Abbreviations

Terms	Description
SPI	Serial Peripheral Interface
USB	Universal Serial Bus
USB-IF	USB Implementers Forum

NOTE – put terms in alphabetical order.

Appendix B – List of Tables & Figures

List of Tables

Table 3.1: FT1248 Commands	6
Table 3.2: CPOL & CPHA Mode Numbers	7
Table 3.3: 1V8 VCCIO timings	9
Table 3.4: 2V5 VCCIO timings	10
Table 3.5: 3V3 VCCIO timings	10

List of Figures

Figure 2.1 FT220X Configured for 1-bit Data	3
Figure 3.1: FT1248 Basic Waveform Protocol.....	4
Figure 3.2: FT1248 Command Structure	5
Figure 3.3: FT1248 Clock Format CPHA = 1.....	8
Figure 3.4: FT1248 Clock Format CPHA = 1.....	9

Appendix C – Revision History

Document Title: AN_206 FT1248 1-BIT SPI
Document Reference No.: FT_000625
Clearance No.: FTDI# 276
Product Page: <http://www.ftdichip.com/FT-X.htm>
Document Feedback: [Send Feedback](#)

Revision	Changes	Date
1.0	Initial Release	2012-02-09